

# SAWGRASS™

THE ART OF WHAT'S NEXT

## Virtuoso User Guide

[sawgrassink.com/Portal/Tech-Support/Technical-Documents/SubliJet-HD/SG400-SG800/Virtuoso\\_Users\\_Guide.aspx](http://sawgrassink.com/Portal/Tech-Support/Technical-Documents/SubliJet-HD/SG400-SG800/Virtuoso_Users_Guide.aspx)

[Home](#) / [SubliJet-HD](#) / Virtuoso User Guide

virtuoso®

SAWGRASS™  
THE ART OF WHAT'S NEXT

User Guide

SG400NA / SG400EU

SG800NA / SG800EU



This User Guide provides information and instructions related to the printer hardware.

[Table of Contents](#) | [Configuring the Printer](#) | [Troubleshooting](#)



Notice: This User Guide provides information and instructions related to the printer hardware.

## Table of Contents

---

### Introduction – Read This First

#### Manuals for this Printer Manuals List

- Important Notice
- User's Notes

#### Information about this Manual

- Symbols
- Note

#### Model-Specific Information

- Available Units and Options for Each Model

### About The Virtuoso SG400 and SG800

#### Guide to Components

- Front View
- Rear View
- Left Side View

#### Options and Accessories

- Option Tray SG400NA / SG400EU
- Option Tray for SG800NA / SG800EU
- Bypass Tray for SG400NA / SG400EU
- Bypass Tray for SG800NA / SG800EU

#### Control Panel

##### Turning On/Off the Power

- Turning on the power
- Turning off the power

### Setup and Installation

#### Setup Procedure

##### Checking the Installation Area

- Installation Area
- Checking the power source

##### Checking the Supplied Items and Unpacking the Printer

##### Attaching and Detaching Options

##### Attaching and Detaching the Option Tray

- Attaching the option tray
- Detaching the option tray

##### Attaching and Detaching the Bypass Tray

- [Attaching the bypass tray](#)
- [Detaching the bypass tray](#)

#### [Loading Transfer Paper / FabricMaker Media](#)

- [Loadable Sizes](#)
- [Handling precautions](#)
- [Storage precautions](#)

#### [Loading Transfer Paper / FabricMaker Media](#)

- [Loading into Tray 1-3](#)
- [Extending the Paper Tray to Load Paper / FabricMaker Media](#)

#### [Installing the Ink Cartridges](#)

#### [Plugging in the Power Cord and Turning the Power On](#)

#### [Connecting the Printer](#)

- [Confirming the Connection Method](#)
- [USB Connection](#)
- [Ethernet Connection](#)

#### [Using the Control Panel to Make Printer Settings](#)

##### [Overview of Settings](#)

##### [Using the \[Paper Input\] Menu](#)

- [Changing the \[Paper Input\] Menu](#)

##### [Using the \[List/Test Print\] Menu](#)

- [Printing a Configuration Page](#)
- [Interpreting the Configuration Page](#)

##### [Using the \[Maintenance\] Menu](#)

- [Nozzle Check](#)
- [Head-cleaning](#)
- [No-fuss head cleaning](#)
- [Head-flushing](#)
- [Head Position](#)
- [Adjust Paper Feed](#)
- [Registration](#)
- [Setting the Date and Time](#)
- [Date setting](#)
- [Time setting](#)
- [Time zone setting](#)
- [De-condensation](#)

##### [Using the \[System\] Menu](#)

- [Changing the \[System\] Menu](#)

##### [Using the \[Host Interface\] Menu](#)

- [Changing the \[Host Interface\] Menu](#)
- [Precautions When Using a Networked Printer](#)

##### [Using the \[Language\] Menu](#)

## Software

### System Requirements

### Design Software Requirements

### Download, Install and Configure Software

## Monitoring and Configuring the Printer

### Using Web Image Monitor

- Displaying Top Page
- Menu
- Logging in Using Web Image Monitor
- Changing the Printer Setting
- Notifying the Printer Status by E-mail
- Specifying notification the printer status by e-mail
- Auto Email Notification: Error Notification by Email:
- Auto Email Notification: Counter Notification: Group
- Auto Email Notification: Detailed Settings for Error Notification
- Auto Email Notification: Counter Notification

## Maintenance

### Ink Cartridges

- Checking the Remaining Ink
- Checking the remaining ink level on the display
- Checking the remaining ink level on the Web Image Monitor
- Checking the remaining ink level via PowerDriver

### Replacing an Ink Cartridge

#### Handling Ink Cartridges

- Waste Collection Unit
- Checking the Waste Ink Level
- Checking the waste ink level on the display
- Checking the waste ink level on the Web Image Monitor
- Checking the waste ink level via PowerDriver
- Replacing a Waste Collection Unit

### Cleaning

- Cleaning the Power Cable Plug

### Moving

- Moving a Short Distance
- Moving a Long Distance

### Disposing

#### When Not Using for a Long Period of Time

## Troubleshooting

### Canceling Printing

- Canceling Printing Using the [Job Reset] Key

- Canceling Printing from the Windows Taskbar
- Canceling a Print Job from the Macintosh Print Job Queue Window

## **Printing Does Not Start**

### **Paper Is Not Fed or Delivered Normally**

#### **Paper Jam**

- Using the [Form Feed] Key to Remove Jammed Paper
- Removing Paper Jammed in Tray 1
- Paper Jam in Tray 2/3
- Removing Paper Jammed in the Bypass Tray
- Removing Paper Jammed under the Top Cover
- Opening the Rear Cover to Remove Jammed Paper
- Removing Paper Jammed in Tray 2/3
- Opening the Rear Unit Cover to Remove Jammed Paper (SG400NA/SG400EU)

#### **Poor Print Quality**

- Prints are Unsatisfactory
- Colors are not correct
- Image Position is not Correct or Only a Partial Image is Printed

#### **Error & Status Messages on the Display**

- Error Messages

#### **Errors Displayed by the Web Image Monitor**

- No Paper/Tray Not Detected (Tray 1)
- No Paper/Tray Not Detected (Tray 2/3)
- No Paper/Tray Not Detected (Bypass Tray)
- Paper Size Mismatch/Paper Type Mismatch (Tray 1)
- Paper Size Mismatch/Paper Type Mismatch (Tray 2/3)
- Paper Size Mismatch/Paper Type Mismatch (Bypass Tray)
- Paper Size Mismatch/Paper Type Mismatch (Auto Tray Select)
- Cover Open
- Cover Open / Ink Cartridge(s) Not Detected
- If the cover is open
- If the ink cartridges are not installed or are installed incorrectly
- Cartridge Almost Empty
- Cartridge Empty
- Used Cartridge
- Waste Collection Unit Not Detected
- Waste Collection Unit Almost Full
- Waste Collection Unit Full
- Used Waste Collection Unit
- Out of Printable Temperature Range
- Printer Error
- Network Interface Error
- Maintenance Failed
- Cannot Recover Error Page

#### **Where to Inquire**

#### **Recommended Consumables**

## Introduction – Read This First

### Manuals for this Printer

Read this manual carefully before using this printer.  
Refer to the sections that are relevant to what you want to do with the printer.

#### Important

##### **Safety Information**

This contains important information about using the printer safely and correctly. Be sure to read this before using the printer.

##### **Quick Installation Guide**

This guide briefly explains how to unpack and install the printer.

##### **User Guide**

This guide explains in detail how to install and use the printer.

The guide also provides instruction on how check and change settings on the printer itself, and how to make and check printer settings using a Web browser.

It contains basic troubleshooting procedures, such as those related to printing and paper jams, and important information about consumables such as paper and ink.

We recommend this guide be installed on the computer so it can be easily referred to.

### Quick Installation Guide

This guide briefly explains how to unpack and install the printer.

### User Guide

This guide explains in detail how to install and use the printer.

The guide also provides instruction on how check and change settings on the printer itself, and how to make and check printer settings using a Web browser.

It contains basic troubleshooting procedures, such as those related to printing and paper jams, and important information about consumables such as paper and ink. We recommend this guide be installed on the computer so it can be easily referred to.

### Manuals List

Manual Name	Printed Manuals Provided	PDF Manuals Provided
Quick Installation Guide	Yes	No
User Guide	No	Yes
Safety Information	Yes	No

### Important Notice

In no event will Sawgrass be liable for direct, indirect, special, incidental, or consequential damages as a result of handling or operating the printer.

For good output quality, Sawgrass recommends that only genuine Sawgrass ink be used. Sawgrass shall not be responsible for any damage or expense that might result from the use of parts other than genuine parts from Sawgrass with the printer.

### User's Notes

- High temperatures inside the printer can cause a breakdown. Do not lean anything against the vent or block it in any way.



- Warm air from the vent is normal and not a cause for concern.
- Do not leave the top or right front cover open. If you do, dust or other matter might get inside the printer, and this will reduce print quality.
- During printing, do not move the printer or open its covers.
- Do not open the top or right front cover during printing. If you do, printing will stop.
- During printing, do not pull out a tray. Printing will stop and the paper will jam.
- Do not touch the feed belt, ink tubes, paper pressing board, or toothed rubber belt. Also, take care not to catch cables or ink tubes with your sleeves.

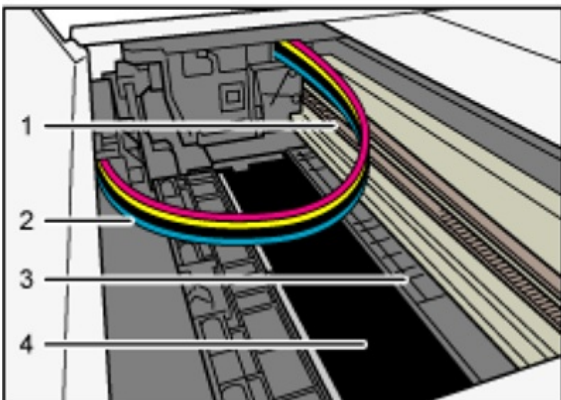

1. *Toothed rubber belt*
2. *Ink tubes*
3. *Paper pressing board*
4. *Feed belt*

- Take care not to let paper clips and other foreign objects fall inside the printer.
- After the ink cartridges are installed and the printer is turned on for the first time, the print head priming process will begin. After it is completed, a head cleaning procedure may be required to achieve a full nozzle check.
- During printing, do not turn off the power or unplug the power cord from the wall outlet.
- During printing, do not subject the printer to external shock such as that caused by tapping paper on it.
- Sawgrass recommends keeping the printer powered on at all times. This will allow the printer to run automatic maintenance utilities for optimal performance.
- Up to 10 kg (22.1 lb.) of evenly spread weight can be placed on the printer. Do not place any concentrated weight of more than 2.5 kg (5.6 lb.) on the printer.
- Do not place unsteady objects on the printer. If they fall, they will cause injury to users and/or damage to the printer.

- The operational life also depends on the environment in which the printer is used.
- The Waste Collection unit may fill up sooner than normal based on the specifics of your printing practices and/or maintenance procedures.
- "Prepare new Waste Collection Unit" message appears shortly before the waste collection unit is full. Although the printer remains usable until the unit is completely full, contact Sawgrass or an authorized distributor to purchase a replacement.
- Ink cartridges should be used up before the "Recommended Use By" date label affixed to each cartridge. Using ink in the printer past this date may be harmful to the unit and/or result in poor output quality.
- Cartridges that the printer report as empty may still contain a small amount of ink. This is normal as the cartridges are overfilled to prevent them from completely running dry. This prevents air from being drawn into the printer.
- Ink cartridges and supplies comply with the manufacturer's safety specifications. To ensure safety and reliability, use genuine Sawgrass ink cartridges and supplies.
- Printing hundreds of copies in a single day might cause nozzle loss the following day. If this happens, perform the head cleaning procedure.
- To ensure consistent print quality this printer performs regular automatic maintenance after and/or during printing. Maintenance is also performed when printing begins after a period of inactivity. A higher than normal amount of ink will be consumed during this maintenance procedure and/or irreversible damage to the print head may occur if printer is not used at least once a month.
- Color ink may be used even when printing all-black or when black and white printing is specified. It may also be used for print head cleaning and refreshing, which are done to maintain printer performance.
- Sawgrass recommends that the printer be used often to ensure the print head nozzles do not become clogged.
- When not in use, do not power off the printer. Leave it powered on so that automatic maintenance utilities can run.
- Note that the printer consumes a considerable amount of ink for maintenance and print head cleaning when used after a long period of inactivity.
- Do not move the printer while it is powered on. Even when it is off, make sure the printer is on a level surface and safe from shock and vibration.
- Do not turn the printer off while it is busy. Make sure the printer is idle before turning it off.
- Condensation can form inside the printer if it is moved from a cold place to a warm place. Allow any condensation to fully evaporate by not turning the printer on for at least an hour after moving it.

## Information about this Manual

Be sure to read this section first to understand how information is presented in this manual. This guide uses Windows 7 for its examples. Procedures and screens might vary depending on the operating system being used.

## Symbols

This manual uses the following symbols:



Indicates points to pay attention to when using the printer and explanations of likely causes of paper misfeeds, damage to originals, or loss of data. Be sure to read these explanations.

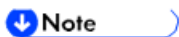

Indicates supplementary explanations of the printer's functions and instructions on resolving user errors.



This symbol is located at the end of sections. It indicates where further relevant information can be found.

[ ]

Indicates the names of keys on the printer's display or control panels.



Differences in the functions of Region A and Region B models are indicated by two symbols. Read the information indicated by the symbol that corresponds to the region of the model being used. For details about which symbol corresponds to the model being used, see the section "[Model-Specific Information](#)".



**NOTE:** Contents of this manual are subject to change without prior notice. Some illustrations in this manual might be slightly different from the actual printer.



## Model-Specific Information

This section explains how to identify the region the printer belongs to.

There is a label on the rear of the printer, located in the position shown below. The label contains details that identify the printer's region.

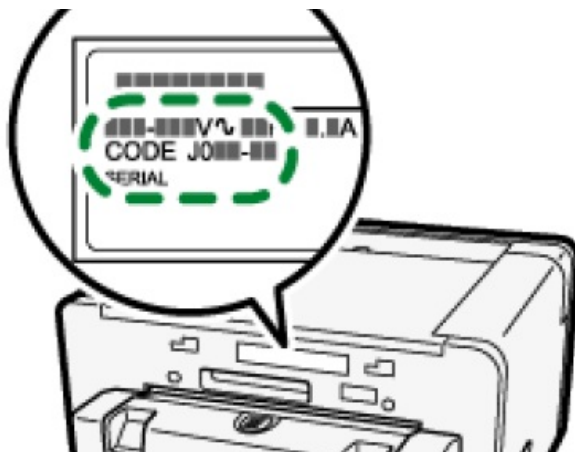

The following information is region-specific. Read the information under the symbol that corresponds to the region of the printer.

 **Region A** (mainly Europe and Asia)

If the label contains the following, the printer is a **region A model**:

- CODE XXXX -22, -27
- 220-240 V

 **Region B** (mainly North America)

If the label contains the following, the printer is a **region B model**:

- CODE XXXX -17
- 100-120 V

### **Note**

Dimensions in this manual are given in two units of measure: metric and inch. If the printer is a **Region A model**, refer to the metric units. If the printer is a **Region B model**, refer to the inch units.

## Available Units and Options for Each Model

The available units and options differ depending on the model.

Unit/Option	SG400NA/SG400EU	SG800NA/SG800EU
Option Tray	Optional	Optional
Bypass Tray	Optional	Optional
Ethernet Interface	Standard Equipment	Standard Equipment
USB2.0	Standard Equipment	Standard Equipment

[Back to top](#)

## About The Virtuoso SG400 and SG800

This chapter describes the names and functions of the printer's parts and options.

### Guide to Components

#### Front View

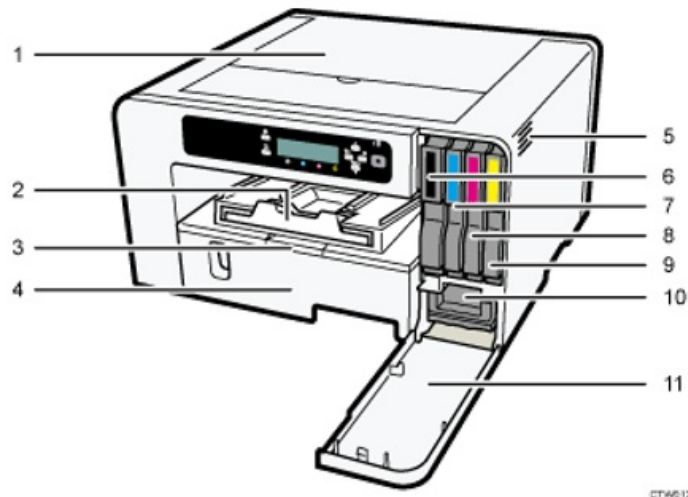

#### 1. Top Cover

*Normally, keep this cover closed. If jammed paper cannot be located or removed easily, you may be able to access it from the top of the printer.*

#### 2. Output Ramp

*Prints are delivered on the output ramp.  
Pull out when using large paper to keep the printed paper from falling.*

#### 3. Paper Tray Cover Extension (SG800NA / SG800EU)

Pull out this cover when using the tray extension to prevent an accumulation of dust. Do not pull out this cover if the extension unit is not used.

#### 4. Tray 1

Load paper / print media here. Use the Tray Extension and Paper Tray Cover Extension for larger paper sizes.

#### 5. Vent

Air is vented here to prevent the inside of the printer from getting too warm. Do not lean anything against the vent or block it in any way. If the inside of

the printer gets too warm, it may not function properly.

## 6. Ink Cartridge (black)

## 7. Ink Cartridge (cyan)

## 8. Ink Cartridge (magenta)

## 9. Ink Cartridge (yellow)

## 10. Waste Collector Unit

## 11. Right Front Cover

Normally, keep this cover closed. Open this cover to install or replace an ink cartridge or the waste collector unit.

### Rear View

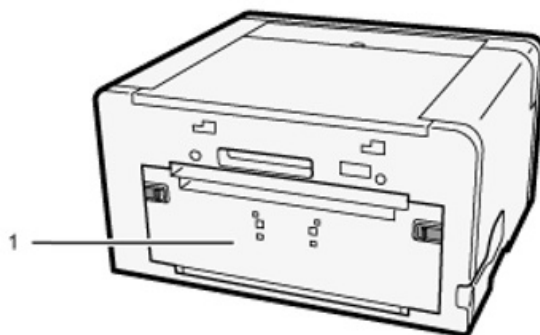

#### 1. Rear cover

Open this to clear paper jams inside the printer.

### Left Side View

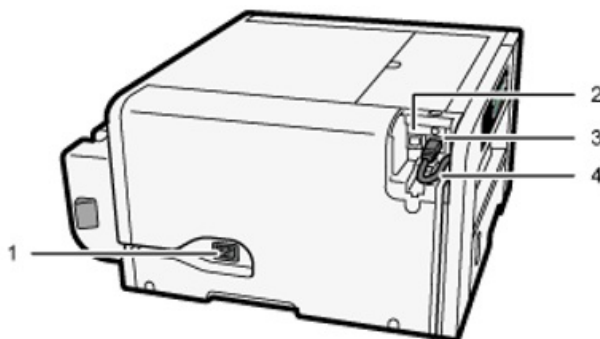

#### 1. Power inlet

Plug for the power cord.

#### 2. USB port

Port for connecting the USB2.0 interface cable.

#### 3. Ethernet port

Port for connecting the 100BASE-TX or 10BASE-T cable.

[Back to the top](#)

## Options and Accessories

### Option Tray SG400NA / SG400EU

This unit allows you to load additional paper / print media. Two units can be stacked.

## Front View

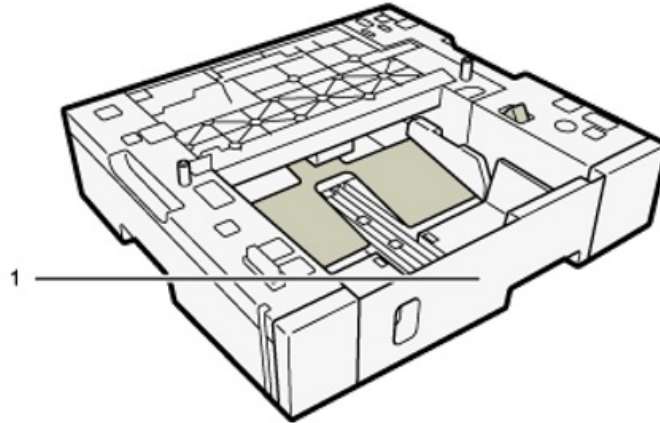

## Rear View

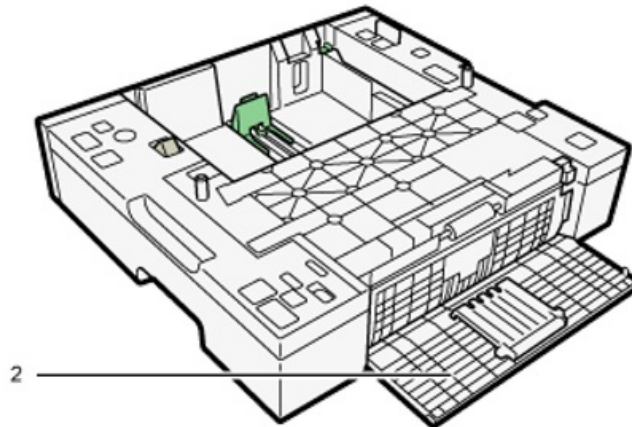

### 1. Tray 2/Tray 3

When using paper larger than A4 or letter, extend the tray.

| *If two option trays are attached, one on top of the other, the unit on top is Tray 2, and the unit on the bottom is Tray 3.*

### 2. Rear unit cover

| *Open to remove paper that has jammed inside the option tray.*

## Option Tray for SG800NA / SG800EU

This unit allows you to load additional paper / print media. Only one unit can be used.

## Front View

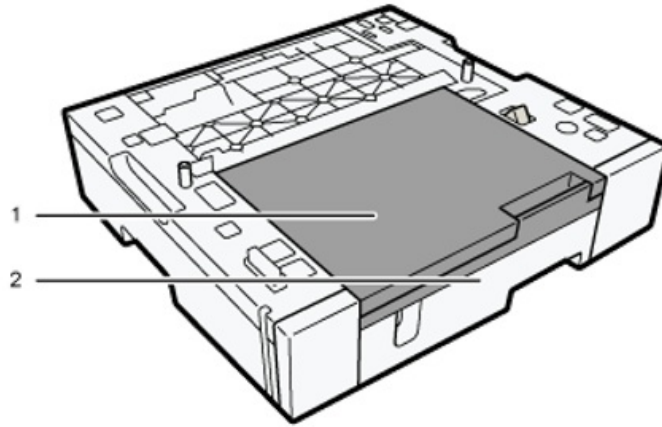

**1. Paper Tray Cover Extension**

Pull out this cover when using the tray extension unit, to prevent an accumulation of dust. Do not pull out this cover if the extension unit is not used.

**2. Tray 2**

To print on paper larger than A4 or letter size, pull the tray extension out.

**Bypass Tray for SG400NA / SG400EU**

Use this tray to feed in sheets manually.

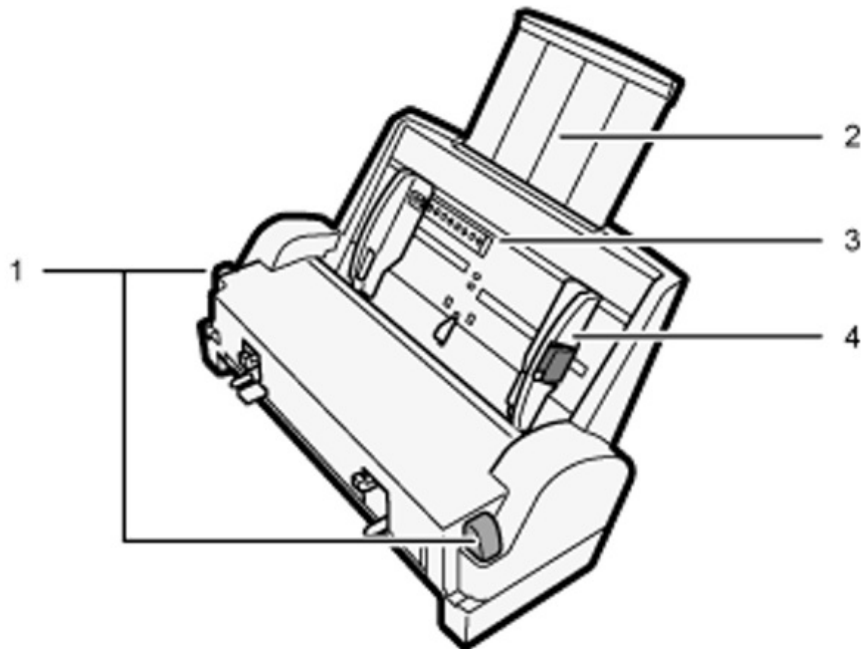

**1. Tabs for bypass tray attachment and detachment**

*Press to lock the bypass tray before attaching it or to unlock the tray before detaching it.*

**2. Bypass tray extension**

*Pull this out according to the paper size.*

**3. Bypass tray**

| Load paper here.

#### 4. Side paper guides

Adjust the position of the side paper guides to match the paper size. Squeeze the locking lever and push the side paper guides.

### Bypass Tray for SG800NA / SG800EU

Use this tray to feed in sheets manually and/or for oversize paper.

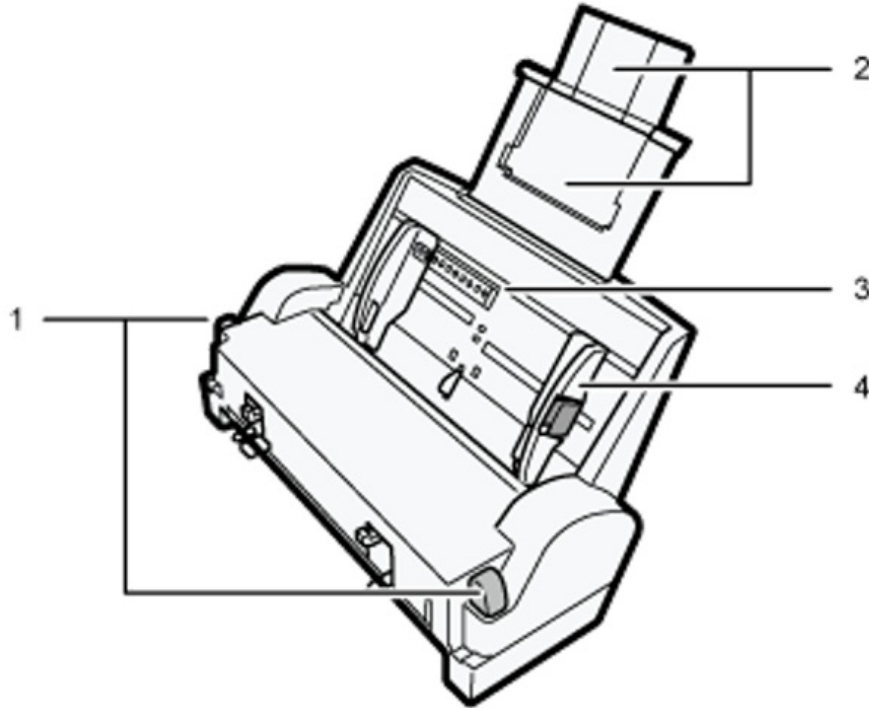

#### 1. Tabs for bypass tray attachment and detachment

| Press to lock the bypass tray before attaching it or to unlock the tray before detaching it.

#### 2. Bypass tray extension

| Pull this out according to the paper size.  
| To load paper larger than A3 or Tabloid, extend the auxiliary trays.

#### 3. Bypass tray

| Load paper here.

#### 4. Side paper guides

| Adjust the position of the side paper guides to match the paper size. Squeeze the locking lever and push the side paper guides.

### Control Panel

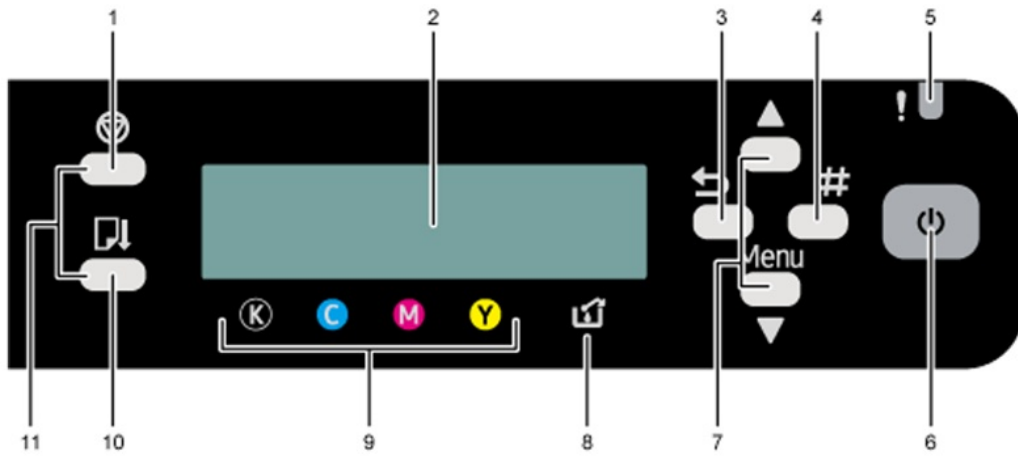

### 1. [Job Reset] key

When the printer is online, press this key to cancel an ongoing print job.

### 2. Display

| Displays the current printer status and messages.

### 3. [Escape] key

| Press this key to return to the previous condition on the display.

### 4. [#Enter] key

| Press this key to execute menu items selected on the display.

### 5. Alert indicator

| Lights up or blinks whenever a printer error occurs.  
If the red light is on, follow the instructions that appear on the display.

### 6. [Power] key

Press this key to turn the power on. To turn the power off, press and hold down this key for one second.

See the section "Turning On/Off the Power" for more information.

Blinks when the printer is receiving data from a computer or if there is data to be printed.

### 7. [ ], [ /Menu] keys

Use these keys to scroll through menu options, increase or decrease values on the display and to change settings.

Keep the key pressed for quick scrolling, and increase or decrease values on the display in units of 10.

To apply this function: under [Maintenance], set [Key Repeat] to [On].

See section "[Using the \[Maintenance\] Menu](#)" for more information.

When the printer is in standby mode, press the [ /Menu] key to make and check the current printer settings.

### 8. Waste ink full indicator

The amount of waste ink is indicated on the six-level display. A message appears when it is near time and time to replace the waste collection unit.

### 9. Cartridge replacement indicator

Each color corresponds to an ink cartridge.

K, C, M, and Y indicate black, cyan, magenta, and yellow, respectively.

The amount of ink remaining in each ink cartridge is indicated on the six-level display.

### 10. [Form Feed] key

Use this to force the printer to print data received when the paper size or type does not match the actual size or type of paper loaded in the tray.

If there is a paper jam, press this key according to the displayed error message and remove the jammed paper.

## 11. No-Fuss Head Cleaning

When the printer is in standby mode, press the [Job Reset] and [Form Feed] keys at the same time to perform head cleaning for all colors.

## Turning On/Off the Power

### ★ Important

- Sawgrass recommends keeping the printer powered on at all times. This will allow the printer to run automatic maintenance utilities for optimum performance.

## Turning on the power

1. Press the [Power] key.

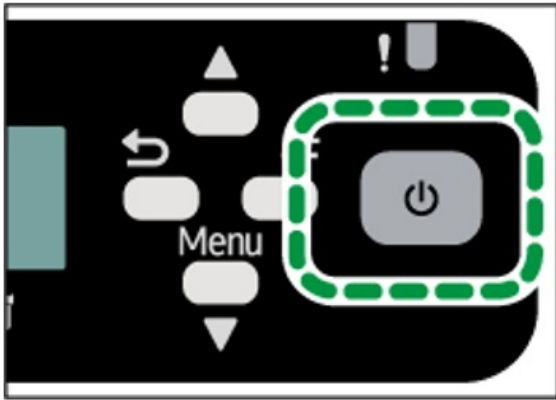

The [Power] key flashes and the "Waiting..." message will be displayed when the printer starts warming up.

The [Power] key lights and the "Ready" message will be displayed when the printer is ready for use.

## Turning off the power

1. Press and hold down the [Power] key for one second.

When the printer is in shutdown mode, the "Shutting down..." message is displayed. When the printer stops, the [Power] key and the display turn off.

### ⓘ Note

If the printer is not used for a specified time after turning it on, it will automatically go into **Energy Saver mode**, and electricity consumption of the printer will be reduced. To specify a wait period for Energy Saver mode initiation, configure the system settings. See section "[Using the \[System\] Menu](#)" for more information.

- If the printer is in Energy Saver mode, the [Power] key lights but the LCD is blank. (SG400NA / SG400EU)
- If the printer is in Energy Saver mode, the [Power] key lights and the "Energy Saver" message will be displayed. (SG800NA / SG800EU)
- The printer recovers from Energy Saver mode when it receives a print job or when any key is pressed.

## Setup and Installation

This chapter describes setup and installation procedures.

### Setup Procedure



	Task	Reference Section for Full Details
1	Check the installation environment	"Checking the Installation Area"
2	Check the supplied items	"Checking the Supplied Items and Unpacking the Printer"
3	Attach any options	"Attaching and Detaching Options"
4	Load paper / FabricMaker media	"Loading Paper / FabricMaker Media"
5	Install the ink cartridges	"Installing the Ink Cartridges"
6	Plug the power cord in and turn the power on	"Plugging in the Power Cord and Turning the Power On"
7	Connect the printer to the computer	"Connecting the Printer"
8	Acquire, install and configure software	"Printer and Color Management Software"

This section explains the tasks necessary for setting up the printer. Install and set up the printer by following the steps in the order shown.

### Important

- Follow these instructions for physical installation of the printer.
- Instructions for installation and configuration of software are provided in separate documents located on [sawgrassink.com](http://sawgrassink.com).
- Do not turn the printer on until you have been instructed to do so.
- Do not connect the printer to a computer via USB until directed to do so in the instructions for software installation.
- Connecting the printer to the computer via USB prior to being instructed to do so may cause the printer to not be automatically recognized resulting in a communication failure with the printer software.

### Checking the Installation Area

The printer's location should be carefully chosen because environmental conditions greatly affect its performance.

### Installation Area

#### ! Warning

- Do not use flammable sprays or solvents in the vicinity of this printer. Also, avoid placing these items in the vicinity of this printer. Doing so could result in fire or electric shock.
- Do not place vases, plant pots, cups, toiletries, medicines, small metal objects, or containers holding water or any other liquids, on or close to this printer. Fire or electric shock could result from spillage or if such objects or substances fall inside this printer.

Be sure to locate the printer as close as possible to a wall outlet. This will allow easy disconnection of the power cord in the event of an emergency.

#### ! Caution

- Keep the printer away from humidity and dust. Otherwise a fire or an electric shock might occur.
- Do not place the printer on an unstable or tilted surface. If it topples over, an injury might occur.
- Do not place heavy objects on the printer. Doing so can cause the printer to topple over, possibly resulting in injury.
- Do not obstruct the printer's vents. Doing so may lead to a fire caused by overheated, internal components.

Make sure the room where the printer is used is well ventilated and spacious. Good ventilation is especially important when the printer is used heavily.

**★ Important**

- To avoid malfunctions, position the printer away from the following:
  - direct sunlight
  - flow of air from air conditioners or heaters
  - radios, televisions, or other electronic devices
  - areas of high/low temperature and high/low moisture
- humidifying appliances
- oil stoves and ammonia-emitting appliances (such as copiers)

Choose a flat, stable area to install the printer.

- The surface should be level within two degrees, left to right and front to back.
- To prevent condensation, install the printer in an area where temperature and humidity conditions do not exceed those indicated in the diagram below.
- The printer may cease to print if these limitations are exceeded. (mainly Europe and Asia)

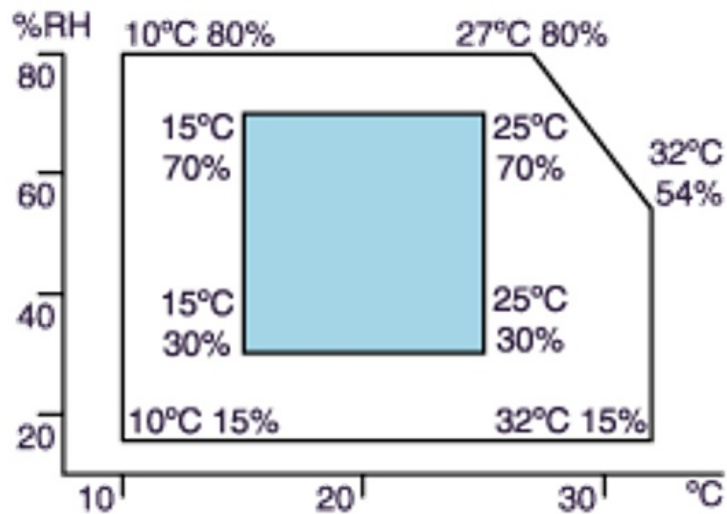

**Region B** (mainly North America)

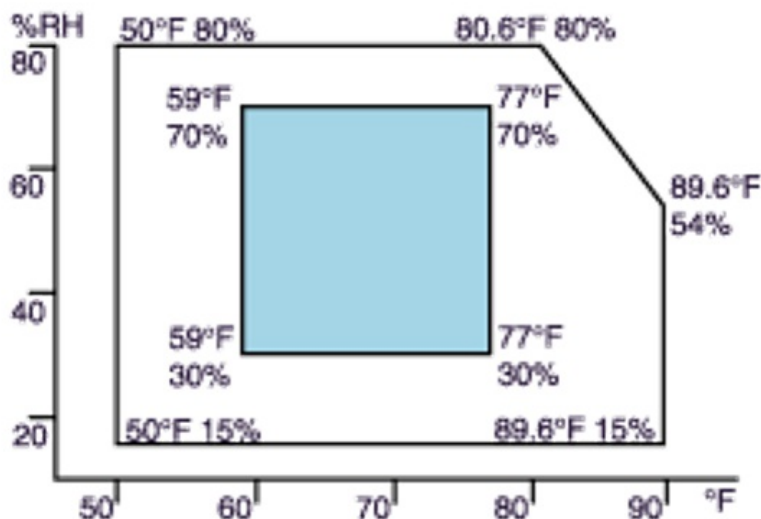

**White area: Permissible Range**

**Blue area: Recommended Range**

- The following diagram shows the **ideal clearance** for loading paper / FabricMaker media, replacing ink cartridges and removing jammed paper.

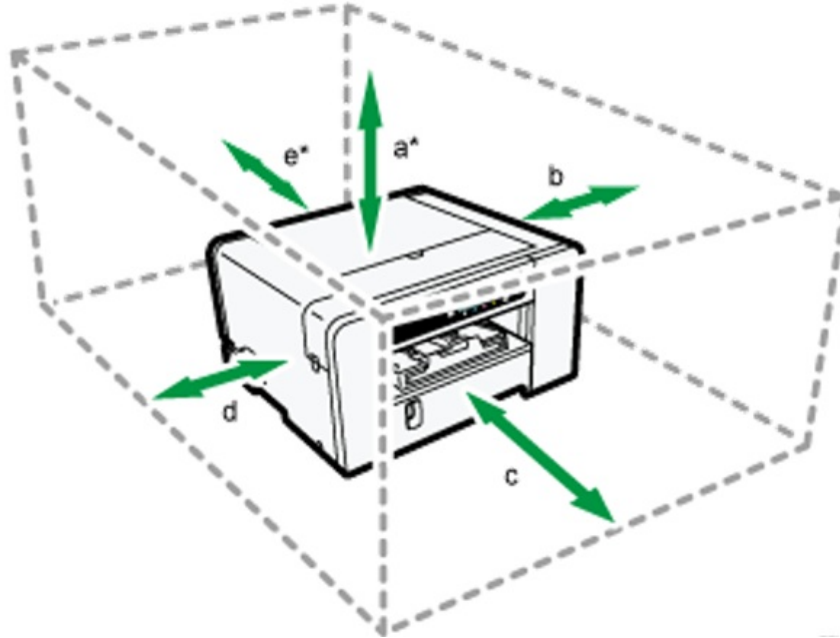

**SG400NA / SG400EU**

1. 26 cm (10.3 inches)
2. 10 cm (4.0 inches)
3. 45 cm (17.8 inches)
4. 3 cm (1.2 inches)
5. 13 cm (5.2 inches)
6. A clearance of 30 cm (11.9 inches) is necessary if the bypass tray is attached.

**SG800NA / SG800EU**

1. 26 cm (10.3 inches)
- A clearance of 41 cm (16.2 inches) is necessary if the bypass tray is attached.

2. 10 cm (4.0 inches)
3. 70 cm (27.6 inches)
4. 3 cm (1.2 inches)
5. 35 cm (13.8 inches)

- A clearance of 38 cm (15.0 inches) is necessary if the bypass tray is attached.

## Checking the power source

### ! Warning

Failure to follow any of the warnings below could result in fire or electric shock:

- Do not use any power sources other than those that match the specifications shown in this manual.
- Do not use any frequencies other than those that match the specifications shown.

Do not use multi-socket adaptors or extension cords

### ! Warning

- Do not touch the prongs of the power cable's plug with anything metallic.
- Do not handle the power cord plug with wet hands.
- The supplied power cord is for use with this printer only. Do not use it with other appliances.
- Do not use power cords that are damaged, broken, or modified. Also, do not use power cords that have been trapped under heavy objects, pulled hard, or bent severely.
- If the power cord is damaged and its inner wires are exposed or broken, contact Sawgrass for a replacement. Use of damaged power cords could result in fire or electric shock.

Be sure to locate the printer as close as possible to a wall outlet. This will allow easy disconnection of the power cord in the event of an emergency.

### ! Warning

- Locate the printer as close as possible to a wall outlet. This will allow easy disconnection of the power cord in the event of an emergency.
- Be sure to push the plug of the power cord fully into the wall outlet. A partially inserted plug may create an unstable connection that can result in unsafe buildup of heat.

When disconnecting the power cord from the wall outlet, always pull the plug, not the cord. Pulling the cord can damage the power cord.



(mainly Europe and Asia)

SG400EU

- 220-240 V: 50/60 Hz 0.6 A SG800EU
- 220-240 V: 50/60 Hz 0.6 A



(mainly North America)

SG400NA

- 100-120 V: 60 Hz 1.0 A SG800NA
- 100-120 V: 60 Hz 1.2 A

## Checking the Supplied Items and Unpacking the Printer

**! Warning:** The following explains the warning messages on the plastic bag used in this product's packaging. **Keep the polythene materials (bags, etc.) supplied with this printer away from babies and small children at all times. Suffocation can result if polythene materials are brought into contact with the mouth or nose.**

**! Caution:** **SG800NA and SG800EU weigh around 15 kg (33 lb.).**

Grip the center area at the base of the printer's sides. Lift it slowly and do not strain your body.

When moving the printer, remove the option. Careless handling and over exertion when lifting can result in breakage and/or injury.

**★ Important**

- Do not turn the printer on until you have been instructed to do so.



- Do not connect the printer to a computer via USB until directed to do so in the instructions for software installation.
- Connecting the printer to the computer via USB prior to being instructed to do so may cause a communication failure between the software and the printer.

Open the printer box and take out all supplied items. Check that all the following items are present:

- Power Cord
- Safety information
- USB Cable

Open the box containing the ink cartridges and other accessories and ensure you have the following:

- Black Sawgrass Ink Cartridge
- Cyan Sawgrass Ink Cartridge
- Magenta Sawgrass Ink Cartridge
- Yellow Sawgrass Ink Cartridge
- Quick Installation Guide
- Warranty Card

- 1. Take off the protective covering.**
- 2. Remove the plastic bag.**
- 3. Lift the printer and move it to the place where it will be installed.**

Grip the indented area at the base of the printer's sides, as shown. Lift and carry the printer slowly and carefully.



#### 4. Remove the tape from the printer body.

#### 5. Attach units and options.

See the section “Attaching and Detaching Options” for more information.

#### ↓ Note

- Sawgrass recommends the box be kept on hand and not disposed.
- 100BASE-TX or 10BASE-T LAN cables are not supplied.

### Attaching and Detaching Options

! Warning:

The following explains the warning messages on the plastic bag used in this product's packaging.

- Keep the polythene materials (bags, etc.) supplied with this printer away from babies and small children at all times. Suffocation can result if polythene materials are brought into contact with the mouth or nose.

### Attaching and Detaching the Option Tray

! Caution:

- SG800NA and SG800EU weigh around 15 kg (33 lb.).
- Grip the center area at the base of the printer's sides. Lift it slowly and do not strain your body.
- When moving the printer, remove the option first. Careless handling and over exertion when lifting can result in breakage and/or injury.

#### ★ Important

- Before installing or removing options, always disconnect the power cord plug from the wall outlet.

### Attaching the option tray

6. If the printer is powered on, press and hold down the [Power] key until it turns off and then unplug the power cord.
7. If necessary, disconnect the USB cable or Ethernet cable.
8. Take the option tray out of the box and remove the tape.

9. Position the option tray close to the printer.

10. Align the connecting parts of the printer and option tray, then lower the printer onto the option tray.

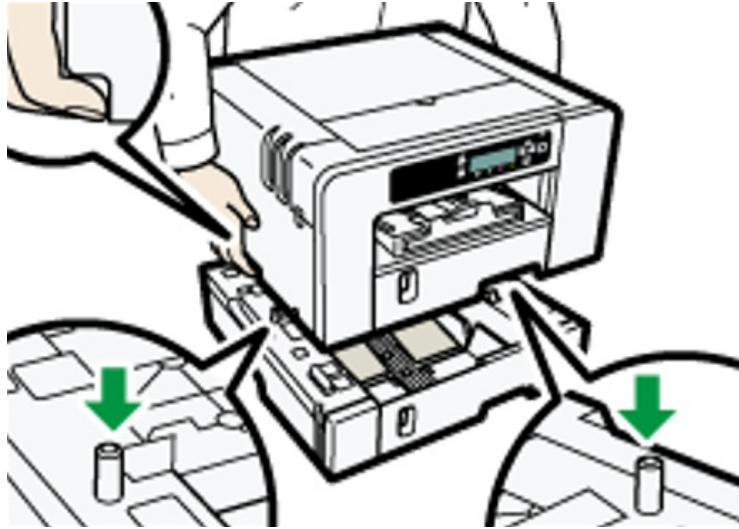

Grip the center area at the base of the printer's sides. Lift it slowly and do not strain your body.

11. Attach the clamping plate and secure it with a coin screw. (SG800NA / SG800EU)

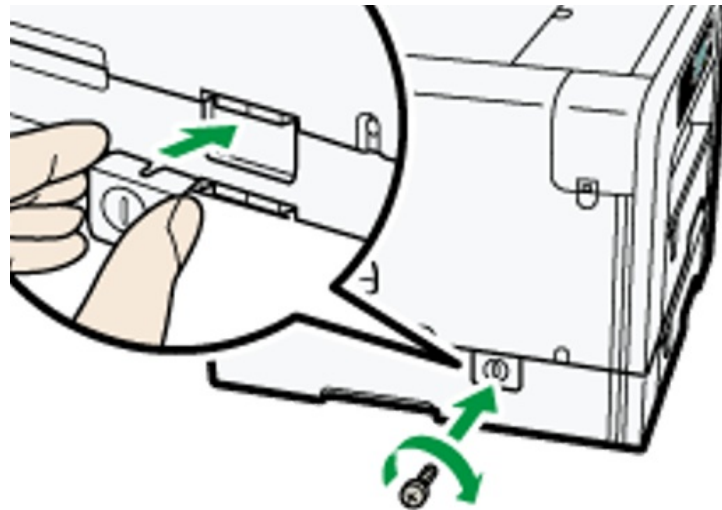

12. Connect the power cord, USB cable or Ethernet cable.

**Note**

- Align the option tray and printer using their corners.
- When the printer is placed on top of the option tray, installation is complete.
- Do not tilt the printer.
- Be careful not to trap your fingers.
- Up to option trays can be attached. (SG400NA / SG400EU)
- To install two option trays, put the upper option tray (Tray 2) on the lower option tray (Tray 3) first, then lower the printer onto the upper option tray (Tray 2).
- After attaching an option tray, the printer driver may need to be configured to recognize it.

- After attaching the option tray, you must register where to start printing on paper loaded in the option tray. See the section "[Registration](#)" for more information.

## Detaching the option tray

1. If the printer is powered on, press and hold down the [Power] key until it turns off and then unplug the power cord.
2. If necessary, disconnect the USB cable or Ethernet cable.
3. Remove the coin screw and then detach the clamping plate. (SG800NA / SG800EU)

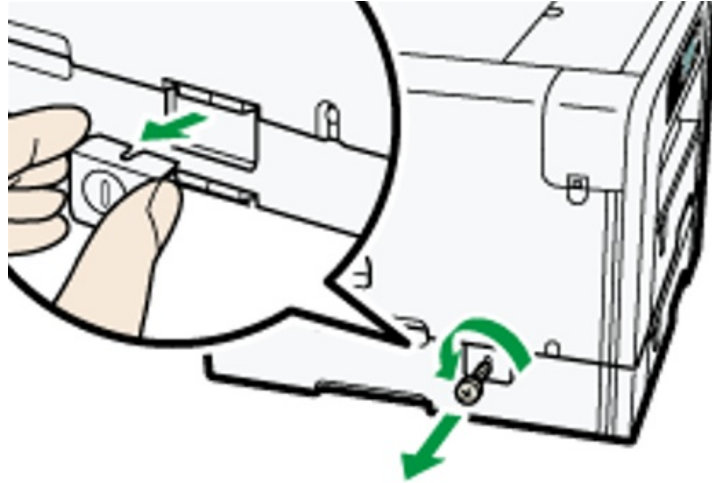

4. Temporarily move the printer to a nearby flat and stable surface to detach the option tray.



Grip the center area at the base of the printer's sides. Lift it slowly and do not strain your body.

5. Place the printer back in the previous location.
6. Connect the power cord, USB cable or Ethernet cable.

### Note

- Do not tilt the printer.
- Be careful not to trap your fingers.

## Attaching and Detaching the Bypass Tray



This section explains how to attach and detach the bypass tray.

! Caution: Do not place the printer on an unstable or tilted surface. If it topples over an injury might occur.

### ★ Important

- Do not place the printer near the edge of a desk if the bypass tray is attached. There is a risk of it falling to the floor.
- Before installing or removing options, always disconnect the power cord plug from the wall outlet.
- Do not forcefully press down on the bypass tray. It may come off the printer and paper misfeeds or positioning problems may result.

### Attaching the bypass tray

1. If the printer is powered on, press and hold down the [Power] key until it turns off and then unplug the power cord.
2. If necessary disconnect the USB cable or Ethernet cable.
3. Take the bypass tray out of the box and remove the tape.
4. Attach the anti-topple stand and then secure it with a coin screw. (SG800NA/SG800EU)

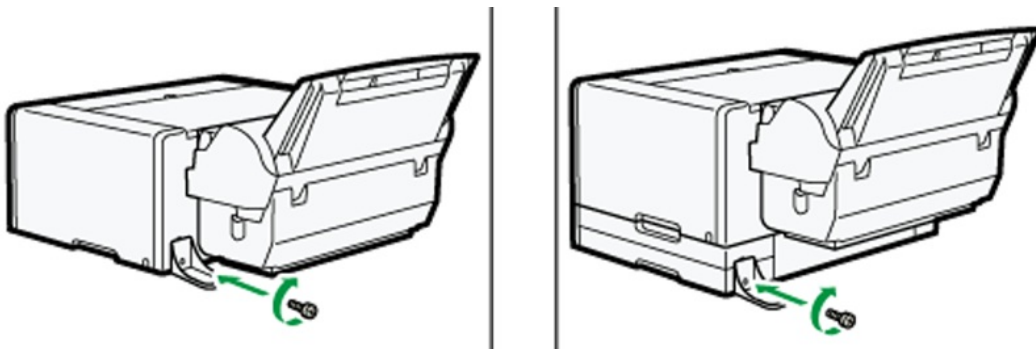

*If an option tray is installed, attach the anti-topple stand to it.*

5. Attach the bypass tray while pressing the tabs on each side, then push it in all the way. Attach the bypass tray into the printer until you hear it click.

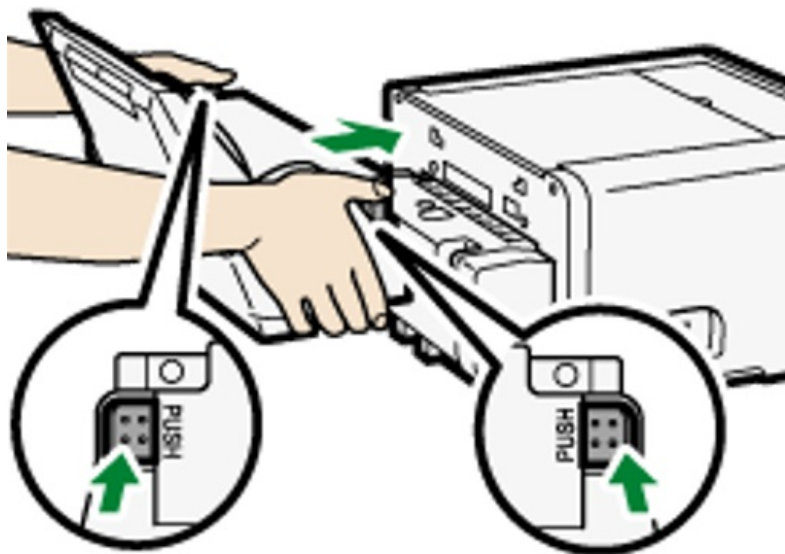

Make sure the tabs return to their original positions.

If the tabs do not return to their original positions, push the tray in while pulling up on its top left part as shown.

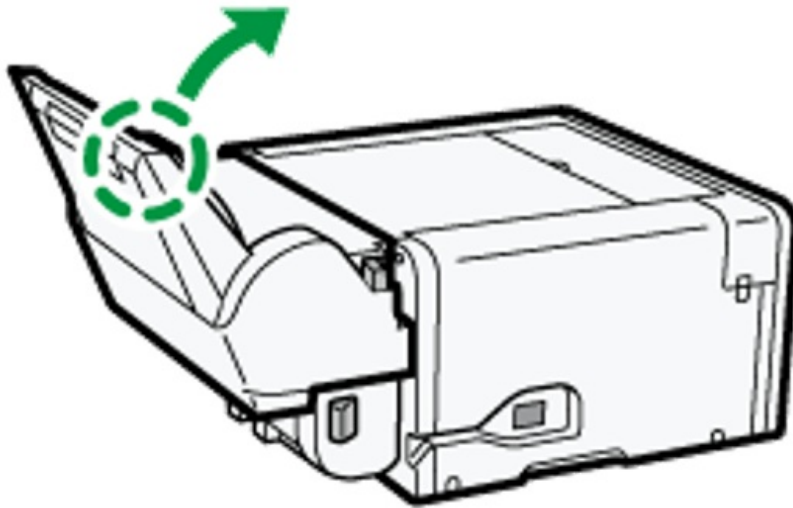

## 6. Connect the power cord, USB cable or Ethernet cable.

### Note

- After attaching an option tray, the printer driver may need to be configured to recognize it.
- After attaching the bypass tray, you must register where to start printing on paper loaded in the bypass tray. See the section "[Registration](#)" for more information.
- The coin screw on the underside of the bypass tray is used when setting the side fence.

## Detaching the bypass tray

### 1. Press and hold down the [Power] key until it turns off, then unplug the power cord.

2. If necessary, disconnect the USB cable or Ethernet cable.
3. Remove any paper / print media in the bypass tray.
4. If the bypass tray extension is pulled out, push it back in.
5. Pressing the tabs on each side of the bypass tray, detach the unit.

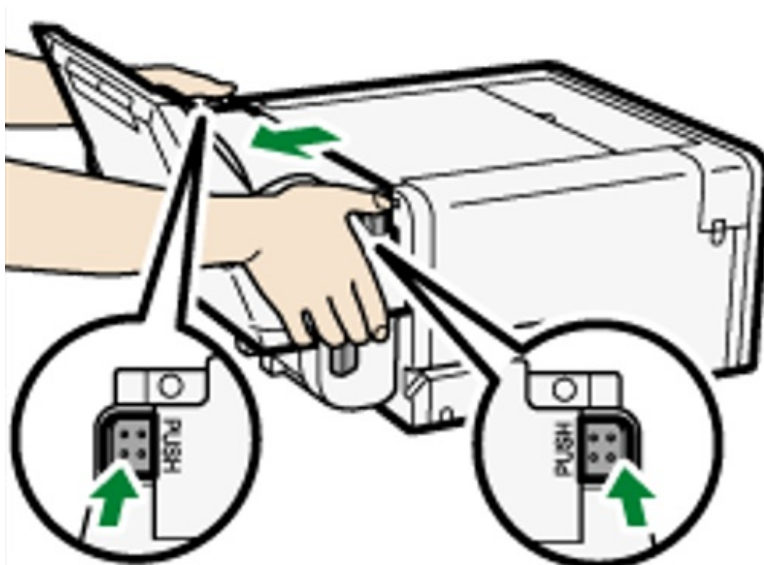

### 6. Connect the power cord, USB cable or Ethernet cable.

## Loading Transfer Paper / FabricMaker Media

This section explains the available paper sizes and how to load paper.

## Loadable Paper Sizes / FabricMaker Media

### Option Tray 1, Option Tray 2, and/or Bypass Tray (SG400NA / SG400EU / SG800NA / SG800EU)

Type	Size	Type	Size
Sublimation Transfer Paper (standard sizes)	A4 (210 × 297 mm)☐	ChromaBlast Transfer Paper	A4 (210 × 297 mm)☐
	A3 (297 × 420 mm)☐		A3 (297 × 420 mm)☐
	A3+ (328 × 483 mm)☐		Letter (8.5 × 11)☐*1
	Letter (8½ × 11)☐*1		Tabloid (11 × 17)☐*1
	Legal (8½ × 14)☐*1		
	Tabloid (11 × 17)☐*1		
	13 × 19☐*1		
Sublimation Transfer Paper (custom cut)	Vertical: 139.7-297.0 mm (5.50-11.69 inches)	FabricMaker Media	Letter (8½ × 11)☐*1 8½" × 10' Roll
	Vertical: 139.7-356.0 mm*1 (5.50-14.01 inches)		
	Horizontal: 88.0-216.0 mm		
	(3.47-8.50 inches)		

\*1  (Mainly North America)

## Handling and Storage Precautions

### Handling precautions

- Load only Sawgrass recommended paper / print media in the paper tray(s).
- Do not load paper / print media of different types or sizes at the same time.
- Pull Trays 1-3 completely out before loading them with paper / print media.
- Load paper / print media in Tray 1-3 print side down with the shorter edge pointing in the paper feed direction. Print side: Sublimation – bright white side. ChromaBlast – side without logo. FabricMaker – fabric side.
- Do not stack paper / print media over the limit mark.

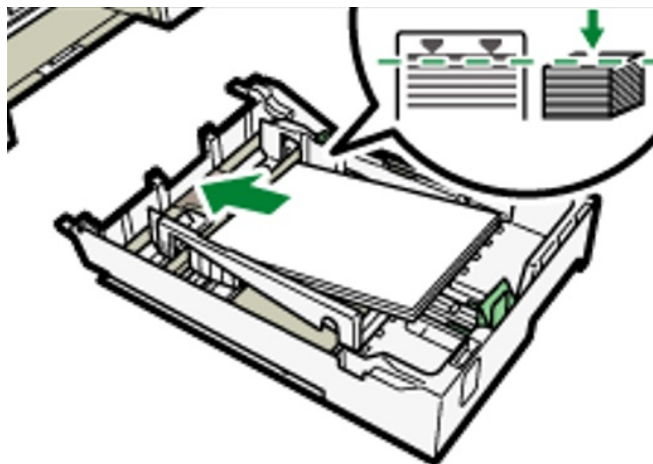

- Load paper / print media in the bypass tray print side up with the shorter edge pointing in the paper feed direction.

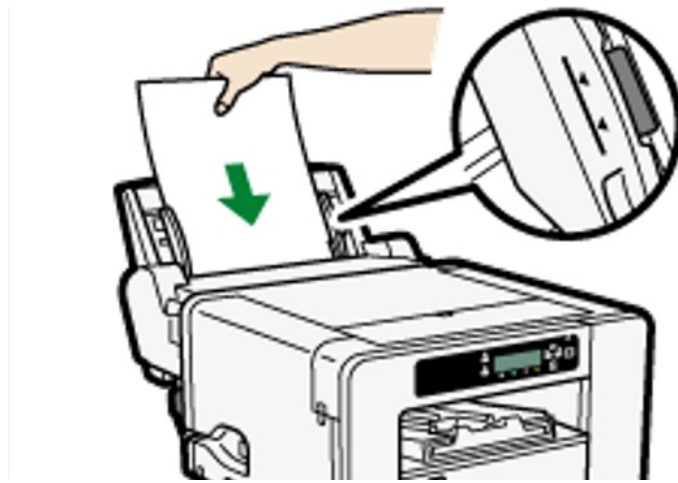

- Curled paper may jam. Straighten any curls within 2 mm (0.08 inches) before loading.

[Back to the top](#)

### Storage precautions

If stored under adverse conditions, even paper suitable for printing can cause paper jams, poor print quality or printer malfunctions. Heed the following when paper is stored:

- Do not store paper / print media in humid places.
- Do not store paper / print media in direct sunlight.
- Store paper / print media flat in the original package.

### Loading Paper / FabricMaker Media

! CAUTION: When loading paper/print media, take care not to trap or injure your fingers.

### Loading Paper / FabricMaker media into Tray 1-3

1. Using the grip, pull the tray halfway out, lift it slightly, then pull it out completely.



Pull the tray out completely. Take care not to drop it.

**2. Pinch the catch of the paper guide on the right side, slide the paper guides to match the size of the paper / print media to load, then push the end paper guide out until there is space between them.**



**3. Load paper / print media with the print side face down but not over the limit mark.**

Print side should be placed face down with the shorter edge pointing in the paper feed direction. Print side: Sublimation – bright white side. ChromaBlast – side without logo. FabricMaker – fabric side.

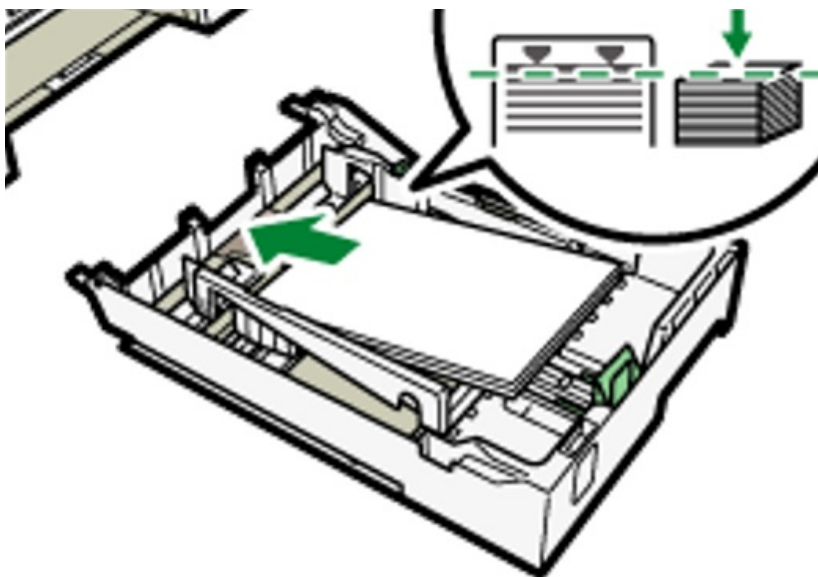

**4. Squeeze the front end paper guide, then slide it to touch the edge of the paper.**



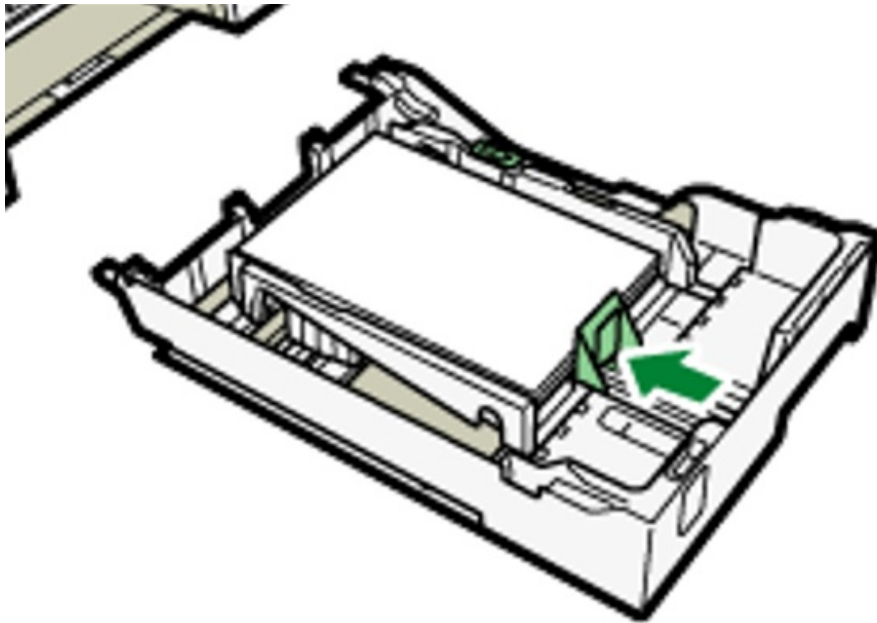

5. Push the tray gently in until it stops.



Before Tray 1 is pushed in, make sure the output ramp is closed.

6. Pull out the output ramp extension.



[Extending the Paper Tray to Load Paper / Print Media](#)

7. Using the grip, pull the tray halfway out, lift it slightly, then pull it out completely.



8. Slide the tabs on both sides of the tray, then release the lock.

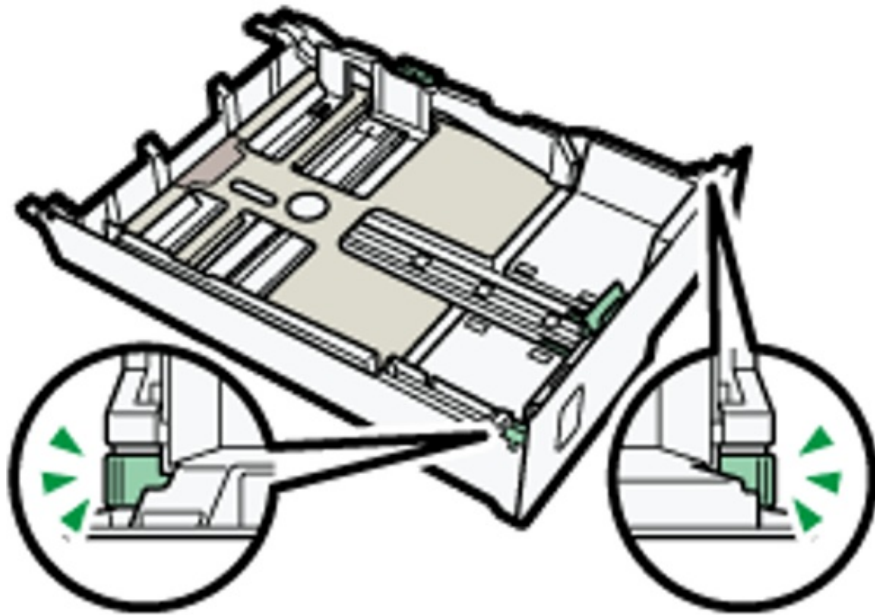

9. Pull out the tray extension.

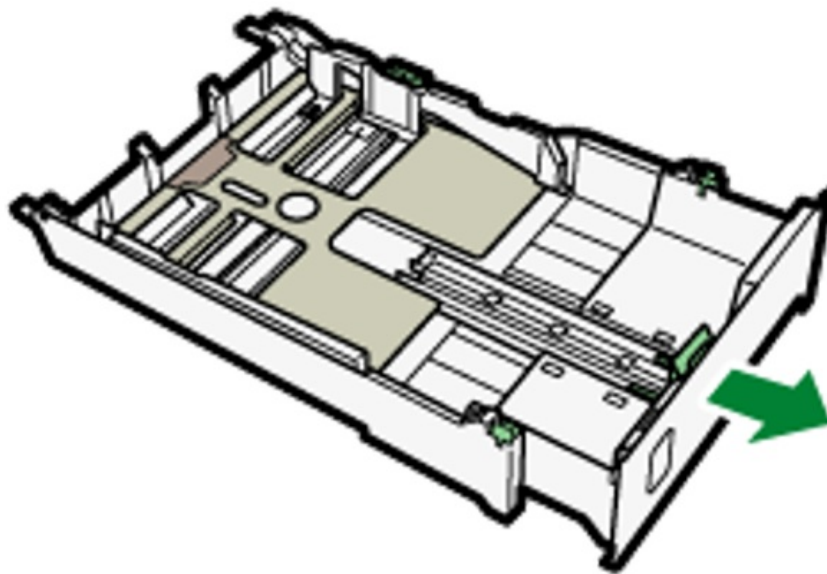

10. Slide both tabs to the original positions, then lock the tray.



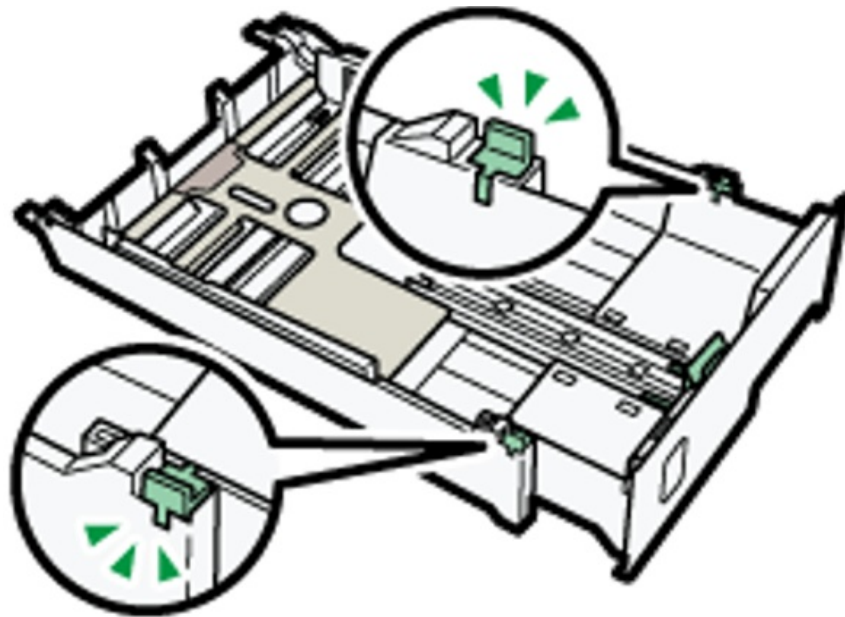

11. Pinch the catch of the paper guide on the right side, slide the paper guides to match the size of paper /print media to load, then push the end paper guide out until there is space between them.



12. Load paper / print media with the print side face down but not over the limit mark.

Print side should be placed face down with the shorter edge pointing in the paper feed direction. Print side: Sublimation – bright white side. ChromaBlast – side without logo. FabricMaker – fabric side.

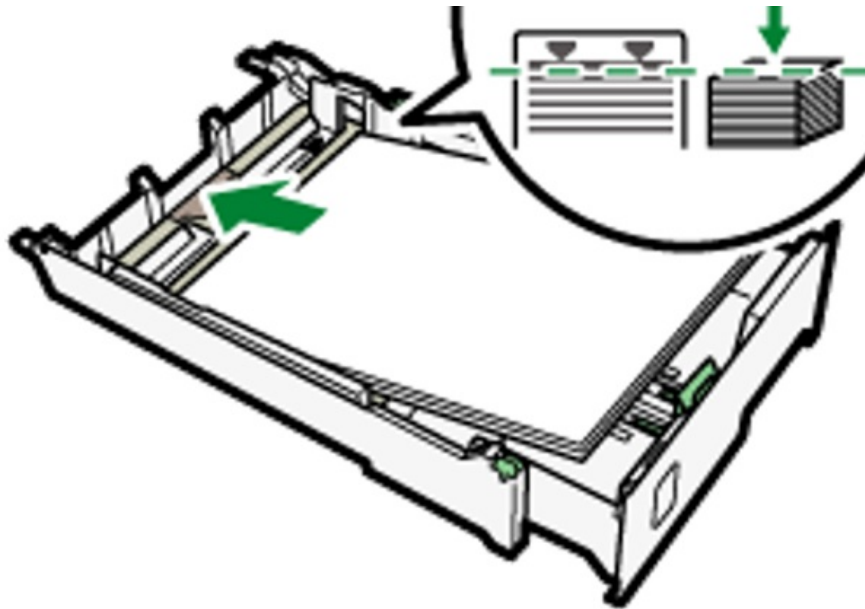

13. Squeeze the front end paper guide, then slide it to touch the edge of the paper.

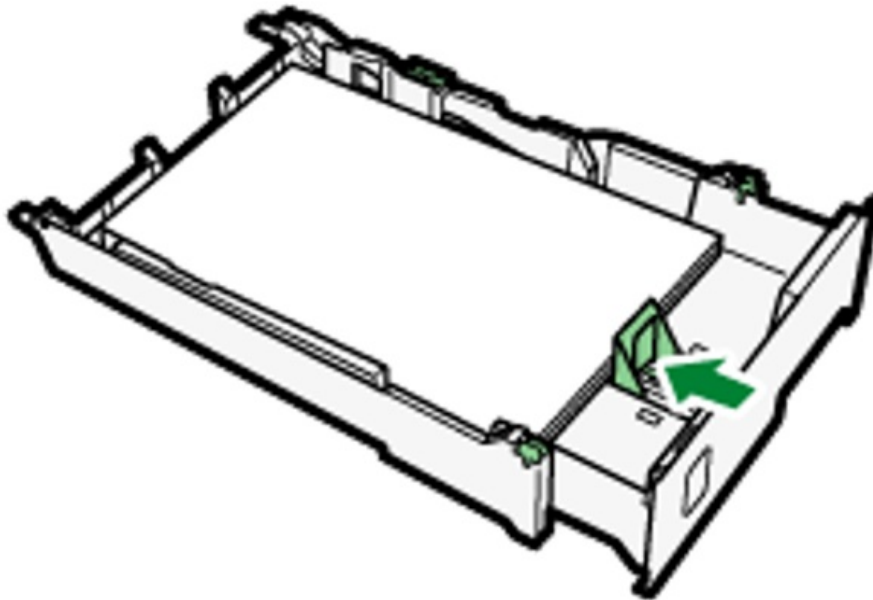

14. Pull out the paper tray cover extension. (SG800NA / SG800EU)



15. Push the tray gently in until it stops.

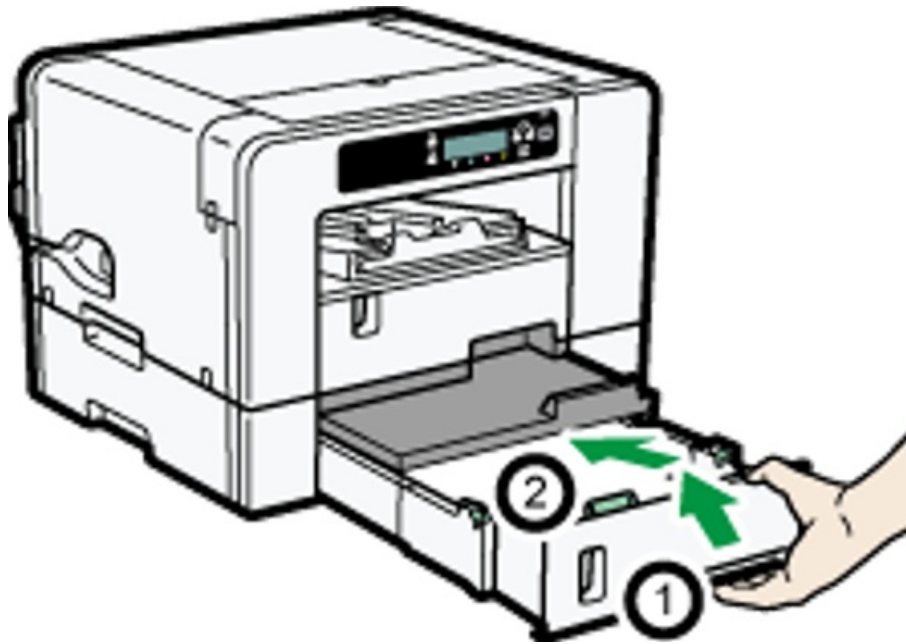

16. Pull out the output ramp extension.



#### **Note**

- Do not use the tray extension for A4 (Letter) size paper or smaller paper.

#### **Important**

- Curled paper / print media may jam. Straighten any curls within 2 mm (0.08 inches) before loading.

## Installing the Ink Cartridges

### ! Caution

Keep ink and ink containers out of reach of children.

If ink gets into contact with eyes, flush eyes with clean, lukewarm water (low pressure) for at least 15 minutes, occasionally lifting eyelids to ensure that the chemical is being flushed out of the eyes. Obtain medical attention.

If ink is ingested, wash out mouth with water provided person is conscious. Consult a doctor immediately.

When removing jammed paper or replacing ink, avoid getting ink on your clothing. If ink comes into contact with your clothing, immediately rinse the stained area with cold water and wash the garment with laundry detergent per the care instructions provided on the label.

When removing jammed paper or replacing ink, avoid getting ink on your skin. If ink comes into contact with your skin, wash the affected area thoroughly with soap and water. If irritation develops, seek medical attention.

When removing the ink cartridge, avoid putting your hand near the place where the ink cartridge is installed. If ink comes in contact with your hands, wash them thoroughly with soap and water. If irritation develops, seek medical attention.

#### **Important**

- When installing the ink cartridge, do not touch the inside of the printer.
- Do not turn the printer on until you have been instructed to do so.



1. Be sure to install the Sawgrass ink cartridges.
2. Remove the packaging from the ink cartridges.  
Do not touch the ink supply ports or chip contacts of ink cartridges.
3. Open the right front cover.



4. Check the orientation of each cartridge, then install them gently.

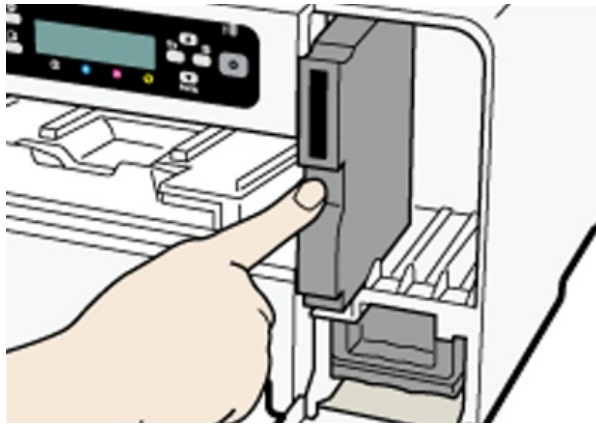

Install in the following order from the left: black, cyan, magenta, and yellow.

**5. Push in each cartridge.**

**6. Repeat steps 3 to 4 for all four cartridges.**

**7. Close the right front cover.**

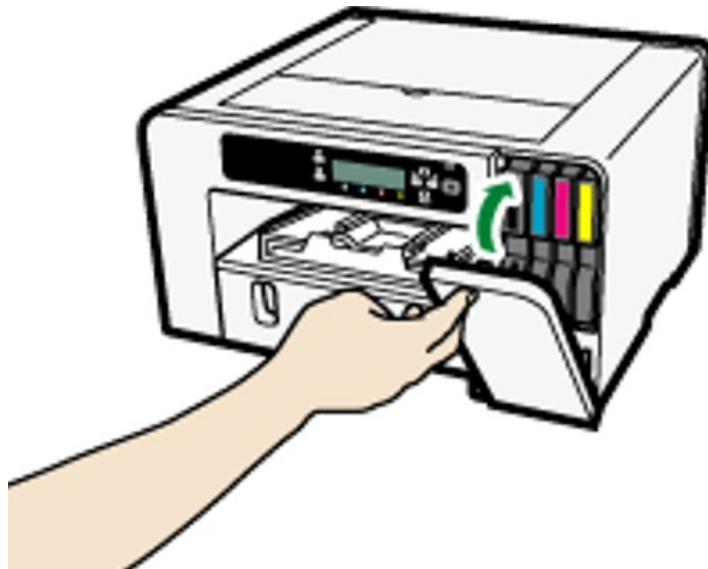

### Plugging in the Power Cord and Turning the Power On

Connect the printer's power cord and turn the printer on but do not connect the printer to a computer yet.

#### Important

- Do not connect the printer to a computer via USB until directed to do so in the instructions for software installation.
- Connecting the printer to the computer via USB prior to being instructed to do so may cause the printer to not be automatically recognized resulting in a communication failure with the printer software.

**! Warning** Failure to follow any of the warnings below could result in fire or electric shock:

Do not use any power sources other than those that match the specifications shown in this manual.

Do not use any frequencies other than those that match the specifications shown.

Do not use multi-socket adaptors or extension cords.

Do not touch the prongs of the power cable's plug with anything metallic.

Do not handle the power cord plug with wet hands.

The supplied power cord is for use with this printer only. Do not use it with other appliances.

Do not use power cords that are damaged, broken, or modified. Also, do not use power cords that have been trapped under heavy objects, pulled hard, or bent severely.

If the power cord is damaged and its inner wires are exposed or broken, contact Sawgrass for a replacement.



**! Caution** Locate the printer as close as possible to a wall outlet. This will allow easy disconnection of the power cord in the event of an emergency. Be sure to push the plug of the power cord fully into the wall outlet. A partially inserted plug may create an unstable connection that can result in unsafe buildup of heat.

When disconnecting the power cord from the wall outlet, always pull the plug, not the cord. Pulling the cord can damage the power cord.

**1. Plug the power cord fully into the printer.**

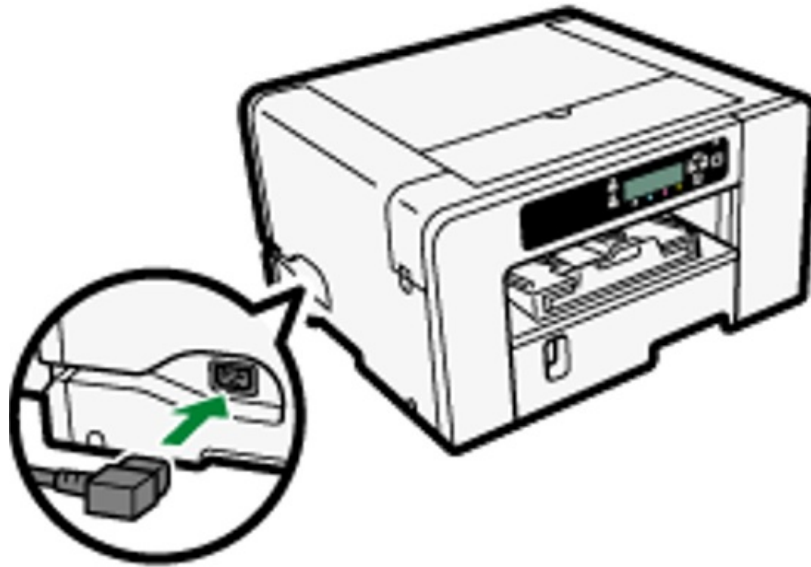

**2. Plug the power cord fully into the wall outlet.**



Make sure the power cord is not trapped under the printer.

**3. Press the [Power] key.**

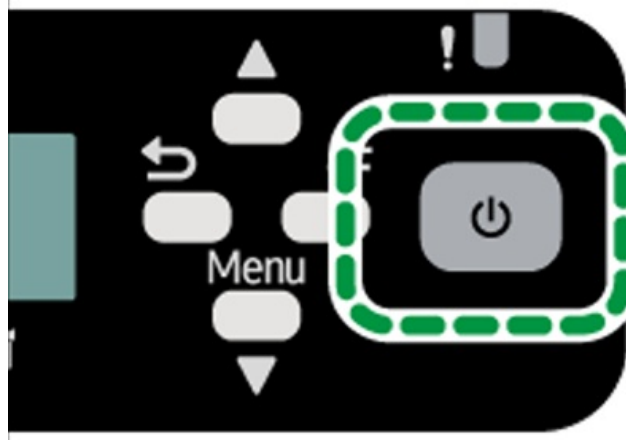

The printer will start performing the initial ink fill.

#### ★ Important

- Do not disturb the printer while it is performing the initial ink fill.
- Leave the printer idle for about six minutes until the message "Ready" appears. Do not remove the plug from the wall outlet while the ink is being fed.
- You may hear a clicking sound while the initial ink fill is being performed. This is not a malfunction and will stop after the process is complete.
- When ink is completely fed, the [Power] key stops flashing and remains lit.

#### ↓ Note

- The amount of ink remaining in the ink cartridges is represented by six levels on the display.
- After installation of the first set of ink cartridges and the initial ink fill, the ink levels on the display will not be at 100%. This is normal and does not mean the ink has been lost or wasted. It is now inside the printer and ready for printing.
- Open the top cover of the printer to view the ink tubes where the initial ink from the first set of cartridges is being stored inside the printer.
- Any subsequent, new ink cartridge will read at the 100% level.

## Connecting the Printer

This section explains how to attach the printer to the computer.

### Confirming the Connection Method

This printer supports both USB and network (100BASE-TX or 10BASE-T Ethernet) connection.

Before installing the software, determine how the printer is connected.

If unsure, begin with the USB installation using the cable provided or contact your network administrator.

### USB Connection

This section explains how to connect the printer to a computer using a USB cable.

#### ↓ Note

- Even if the computer connected to the printer via USB is networked, you can still connect the printer and computer according to the procedure explained in this section.

#### ★ Important

- Do not turn the printer on until directed to do so during the installation of software.





1. Make sure the printer is off.
2. Open the port cover.

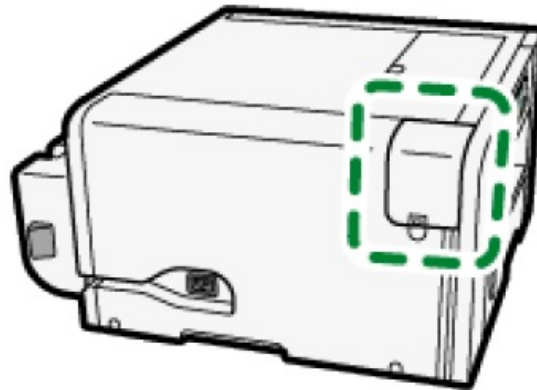

3. Insert the USB cable's hexagonal (type B) plug firmly into the port.

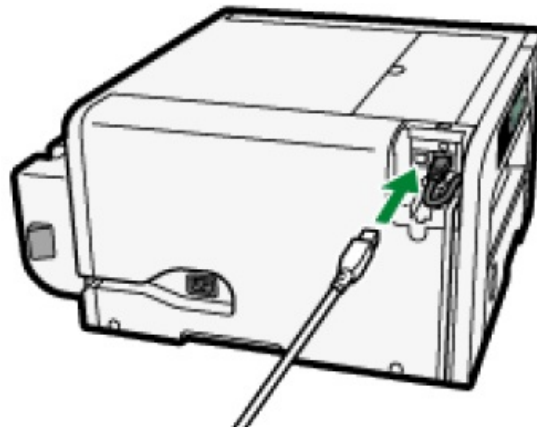

4. Close the port cover.

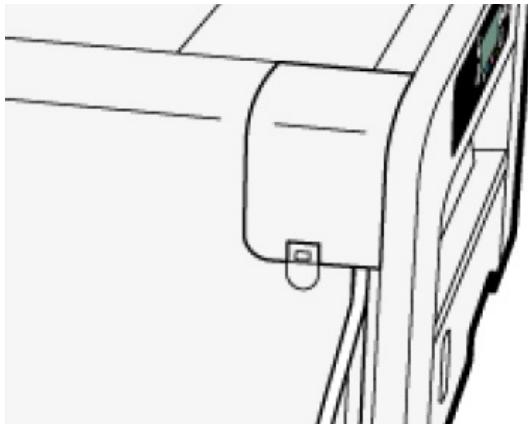

5. Insert the USB cable's rectangular (type A) plug firmly into the computer's USB port.

**Note**

- Check the shape and orientation of the USB cable's plug and insert it fully.

### Ethernet Connection

This section explains how to connect the printer to a computer using Ethernet.

Be sure to install all necessary network equipment, such as hubs, etc. before connecting the Ethernet cable to the printer.

Connect the printer via Ethernet first, then specify the printer's network settings according to the network environment.

**Important**

- Ethernet cables are not supplied with the printer. Select your cable according to the network environment.
- You can connect a 10BASE-T or 100BASE-TX cable to the printer.

1. Open the port cover.

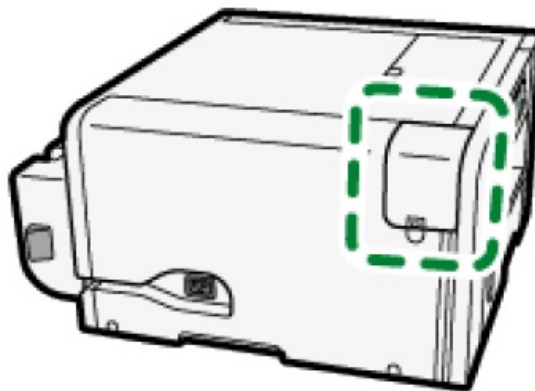

2. Plug the Ethernet cable into the port.

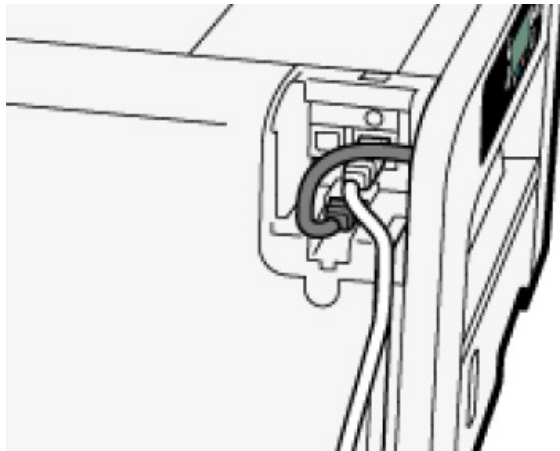
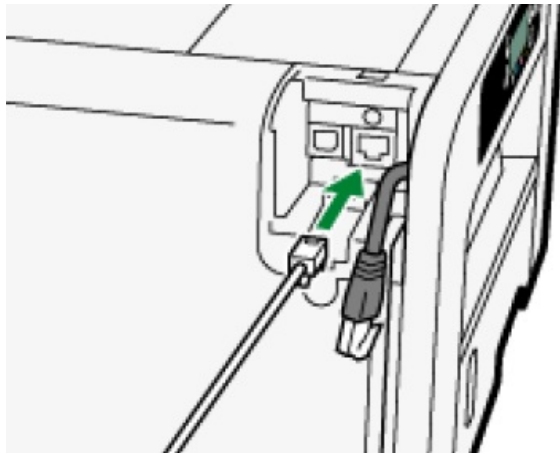

**3. Connect the other end of the cable to the printer's network, such as to a hub.**

When the printer has been powered on, you can check the LEDs on the Ethernet port.



- **Indicator (green)**

Lights whenever the printer is properly connected to the network.

- **Indicator (yellow)**

Lights whenever the printer is sending or receiving data via the network.

**4. Close the port cover.**

## Note

- Network settings may need to be changed according to the network interface you are using.
- See section "Using the [Host Interface] menu" for information on the settings that can be specified and their default factory values.

## Using the Control Panel to Make Printer Settings

This chapter describes use of the printer's control panel to make changes to various printer settings.

### Overview of Settings

#### Paper Input

You can configure the paper tray settings.

Menu
Tray Paper Size
Paper Type
Auto. Tray Select
Tray Priority

See section "Using the [Paper Input] Menu" for more information.

#### List/Test Print

You can check the printer's present settings and operational status.

Menu
Config. Page
Color Demo Page
Error Log
PCL Config. Page

See the section "Using the [List/Test Print] Menu" for more information.

#### Maintenance

You can adjust the print quality.

Menu
Nozzle Check
Head-cleaning
Head-flushing
Head Position
Adj. Paper Feed
Registration
Date/Time
Key Repeat
Dry-delay (Exit)
Dry-delay (Dup)
Paper Feed Test
De-condensation

See section "Using the [Maintenance] Menu" for more information.

Language

You can select which language the menu is displayed in. North American and European versions are different. Language options for these printers may vary.

Menu
English
German
French
Italian
Dutch
Danish
Swedish
Norwegian
Spanish
Finnish
Portuguese
Czech
Polish
Hungarian

The [Language] menu will be displayed in English.

See section "[Using the \[Language\] Menu](#)" for more information.

## Using the [Paper Input] Menu

This section explains the settings you can specify in the [Paper Input] menu, such as those for the size and type of the paper / print media loaded in each paper tray, although changes in this manner are not recommended by Sawgrass.

### Tray Paper Size

*You can specify the size of the paper / print media loaded in the paper tray.*

#### ★ Important

Sawgrass recommends that you do not change the paper size in this manner since it may conflict with settings controlled by the printer driver.

### Paper Type

You can specify the type of the paper loaded in the paper tray.

#### ★ Important

Sawgrass recommends that you do not change the type of paper in this manner since it may conflict with settings controlled by the printer driver.

### Aut.Tray Select

Specify that the paper tray be automatically selected. The paper tray will automatically be selected according to the paper size and paper type.

### Tray Priority

You can specify the prioritized paper tray. Default: [Tray 1]

#### ↓ Note

- "Aut.Tray Select" can be specified only if the bypass tray or the option tray is attached.
- If you select "Aut.Tray Select", the paper tray is automatically selected according to the paper size and paper type for the paper trays in "Tray Paper Size" and "Paper Type".
- "Tray Priority" will be specified only if the option tray is attached.

## Changing the [Paper Input] Menu

The following procedure is an example of setting the Tray Paper Size, although changes in this manner are not recommended for use with the Sawgrass PowerDriver.

1. Press the [  /Menu] key.

2. Press the [  ] or [  /Menu] key to display [Paper Input], then press the [#Enter] key.

Menu:

Paper Input

3. Press the [  ] or [  /Menu] key to display [Tray Paper Size], then press the [#Enter] key.

Paper Input:

Tray Paper Size

4. Press the [  ] or [  /Menu] key to display the paper tray you want to specify, then press the [#Enter] key.

Tray Paper Size:

Tray 1

5. Press the [ ] or [ /Menu] key to display appropriate paper size, then press the [#Enter] key.

Tray 1:

\*A4 (210 x 297)

6. Press the [Escape] key.

[Back to the top](#)

## Using the [List/Test Print] Menu

Use the [List/Test Print] menu to check that the printer is working properly and to also check the printer's system configuration and settings.

### Config. Page

You can print the current configuration of the printer.

### Color Demo Page

You can print a sample image, but do not use the output to judge output quality or imaging issues.

### Error Log

You can print error logs.

## Printing a Configuration Page

1. Press the [ /Menu] key.



2. Press the [  ] or [  /Menu] key to display [List/Test Print], then press the [#Enter] key.

Menu:

List/Test Print

3. Press the [▲] or [▼/Menu] key to display [Config. Page], then press the [#Enter] key.

List/Test Print:

Config. Page

The configuration page is printed.

4. Press the [Escape] key.

## Interpreting the Configuration Page

### System Reference

Information such as the counter numbers (Pages Printed), the printer's firmware version, attached options, language and remaining ink are printed in this area.

### Paper Input

The specified Tray Priority setting and the specified settings in the [Paper Input] menu, such as the size and type of paper loaded in each paper tray, are printed in this area.

### Maintenance

The specified settings in the [Maintenance] menu are printed in this area.

### System

The specified settings in the [System] menu are printed in this area.

### Host Interface, Interface Information

The specified settings in the [Host Interface] menu are printed in this area.

### Language

The selected language in the [Language] menu is printed in this area.

## Using the [Maintenance] Menu

Use the [Maintenance] menu to specify printer maintenance settings.

### Nozzle Check

Print a test pattern to check that print head nozzles are printing properly.

If nozzle blockages occur, ink cannot be ejected properly. This will result in poor print quality.

### Head-cleaning

Clean the print head if the test pattern indicates the nozzles are not printing properly. Head cleaning consumes ink but is sometimes necessary to achieve a full nozzle check.

#### Important

Perform a head cleaning up to five (5) times.

Print and check for any changes in the nozzle check test pattern between each head cleaning.

### Head-flushing

Perform a more thorough head cleaning if print head nozzles cannot be cleared by up to five (5) head cleanings.

#### Important

Head flushing consumes more ink than head cleaning. Do not perform more than one (1) head flush.

If nozzles do not print properly after five (5) head cleanings and one (1) head flush, contact Sawgrass for assistance.

### Head Position

Adjust the print head to resolve some print quality problems such as printed lines that are vertically misaligned.

#### Important

- Although instructions are provided, Sawgrass recommends that the procedure to adjust the print head be performed from the printer driver and not the printer control panel.

## Adj. Paper Feed

If printed lines are horizontally misaligned or if images are printed unevenly, print the test pattern and adjust the paper feed setting.

### Important

- Although instructions are provided, Sawgrass recommends that the procedure to adjust the paper feed be performed from the printer driver and not the printer control panel.

## Registration

Print the test pattern and align the point where printing starts for each paper tray.

## Date/Time

You can specify the date and time.

## Key Repeat

The key repeat function allows you to specify setting values in units of ten or scroll the display quickly by pressing and holding down the [▲] or [▼] /Menu] key.

Default: [On]

## Dry-delay (Exit)

To prevent spoiling of printed copies, select a print delivery interval to allow them to dry. The interval must be long enough to allow a sheet to dry. You can specify an interval between 1 and 20 seconds.

Default: [Off]

## Paper Feed Test

You can eject a sheet of paper without printing anything on it.

## De-condensation

To remove moisture from inside the printer, you can eject three sheets of paper without printing anything on them.

## Nozzle Check

Follow the procedure below to print a nozzle check test pattern used to check if the print head nozzles are printing properly.

**1. Press the [▼] /Menu] key.**

**2. Press the [▲] or [▼] /Menu] key to display [Maintenance], then press the [#Enter] key.**

Menu:

Maintenance

**3. Press the [▲] or [▼] /Menu] key to display [Nozzle Check], then press the [#Enter] key.**

Maintenance:

Nozzle Check

**4. Press the [#Enter] key.**

Press # to

print pattern

**A test pattern is printed.**

**5. Press the [Escape] key.**

**6. Check the printed test pattern.**

Printed Test Pattern



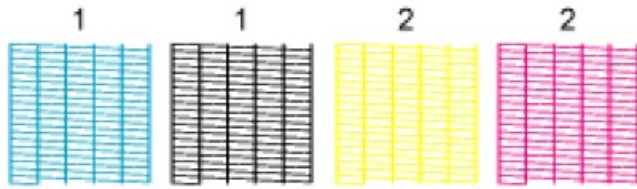

Using the printed test pattern, check for missing nozzles.

The number above each color in the test pattern is the number of the print head. The print head for cyan and black is [Head 1].

The print head for yellow and magenta is [Head 2].

Check which print head is missing nozzles by referring to the following illustration.

### Normal

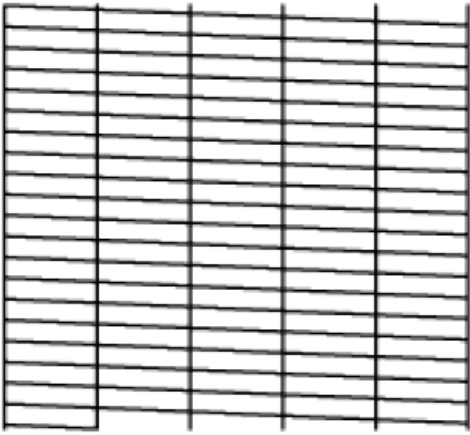

### When a print head is missing nozzles

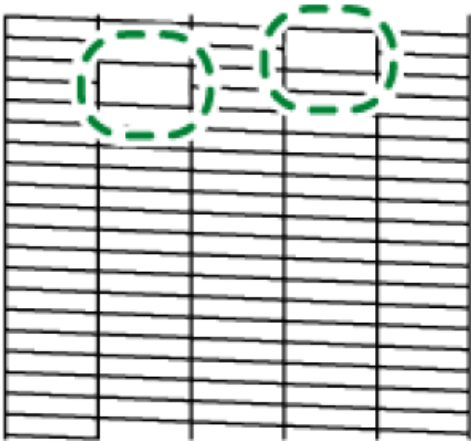

If the print head is missing nozzles, perform a Head Cleaning. See section "[Head- cleaning](#)" for more information.

If the problem persists, perform Head Flushing. See section "[Head-flushing](#)" for more information.

### Head-cleaning

Follow the procedure below to perform a print head cleaning.

Perform a head cleaning when print quality is affected by missing nozzles.

Head cleaning consumes ink but is sometimes necessary to achieve a full nozzle check. After an ink cartridge is replaced, a print head cleaning will be automatically performed.

## ★ Important

- Perform a head cleaning up to five (5) times in an attempt to clear missing nozzles.
- Print and check for any changes in the nozzle check test pattern between each head cleaning.
- Do not turn the printer off during print head cleaning. If the printer is turned off during a print head cleaning, start again by printing a nozzle check test pattern.

1. Press the [▼/Menu] key.

2. Press the [▲] or [▼/Menu] key to display [Maintenance], then press the [#Enter] key.

Menu:

Maintenance

3. Press the [▲] or [▼/Menu] key to display [Head-cleaning], then press the [#Enter] key.

Maintenance:

Head-cleaning

4. Press the [▲] or [▼/Menu] key to select a color, then press the [#Enter] key.

Head-cleaning

All Heads

To clean all the print heads, select [All Heads].

To clean the print head for cyan and black, select [Head 1].

To clean the print head for yellow and magenta, select [Head 2].

5. Press the [#Enter] key.

Press # to

clean heads

### Head cleaning starts

Maintenance

in process...

6. Press the [Escape] key.

## No-fuss head cleaning

You can perform a one-touch head cleaning for all colors.

1. Press the [Job Reset] and [Form Feed] keys at the same time.

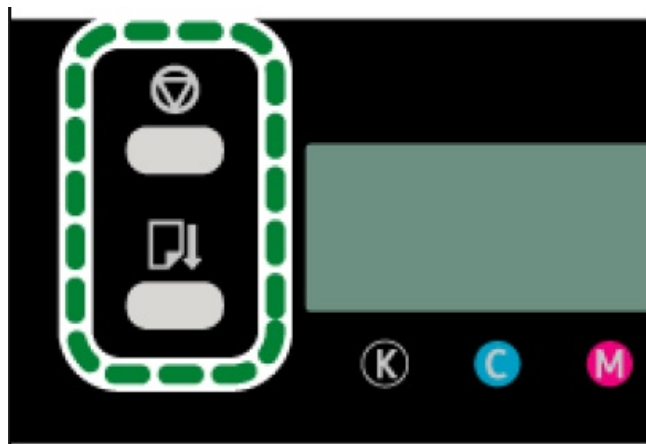

The following message appears:

Press # to  
clean heads

## 2. Press the [#Enter] key.

Head cleaning starts.

## Head-flushing

Follow the procedure below to perform a thorough print head cleaning.

### Important

- Perform a head flushing only if print head nozzles cannot be cleared by up to five (5) head cleanings.
- Head flushing consumes more ink than head cleaning.
- Do not perform more than one (1) head flush.
- If nozzles do not print properly after up to five (5) head cleanings and one (1) head flush, contact Sawgrass for assistance.
- Do not turn the printer off during print head flushing. If the printer is turned off during print head flushing, start again from printing the nozzle check test pattern.

### 1. Press the [▼/Menu] key.

### 2. Press the [▲] or [▼/Menu] key to display [Maintenance], then press the [#Enter] key.

Menu:

Maintenance

### 3. Press the [▲] or [▼/Menu] key to display [Head-flushing], then press the [#Enter] key.

Maintenance:

Head-flushing

### 4. Press the [▲] or [▼/Menu] key to select a color, then press the [#Enter] key.

Head-flushing:

All Heads

*To clean all the print heads, select [All Heads].*

*To clean the print head for cyan and black, select [Head 1].*

*To clean the print head for yellow and magenta, select [Head 2].*

### 5. Press the [#Enter] key.

Press # to

flush heads

Head flushing starts.

Maintenance

in process...

### 6. Press the [Escape] key.

## Head Position

Adjusts the print head. Perform this operation if printed lines are vertically misaligned.

### Important

- Although instructions are provided, Sawgrass recommends that the procedure to adjust the print head be performed from the printer driver and not the printer control panel.

If there are several lines in the test pattern, check adjustment values for each line, and adjust the print head positions. If the adjustment value is set to "0", adjustment is not necessary. Adjust all lines so their adjustment values indicate "0".

1. Press the [▼/Menu] key.

2. Press the [▲] or [▼/Menu] key to display [Maintenance], then press the [#Enter] key.

Menu:

Maintenance

3. Press the [▲] or [▼/Menu] key to display [Head Position], then press the [#Enter] key.

Maintenance:

Head Position

4. Press the [▲] or [▼/Menu] key to display

Head Position

Pr. Test Pattern

5. Press the [▲] or [▼/Menu] key to select the target's resolutions, then press the [#Enter] key.

Pr. Test Pattern:

High Speed

A test pattern to adjust print head positions is printed.

6. To determine the adjustment value, select the square that is faintest (closest to white). Alternatively, select the square whose internal lines overlap to form a single color.

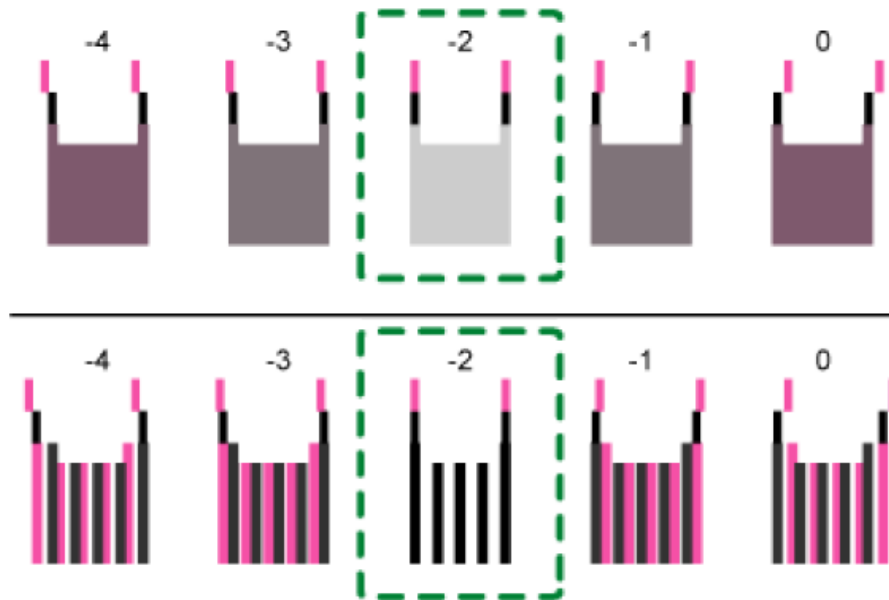

Combined two-color lines form squares, and depending on line overlapping, (white) spaces between the lines are painted and look darker. Sometimes the colors of the lines are identical.

For this illustration, the adjustment value is "-2". Checking adjustment values for each item is required.

- If you cannot determine the adjustment value, select the square that is between the straightest lines.

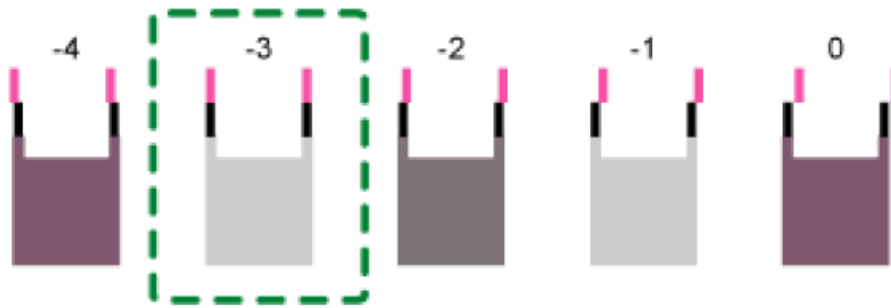

Each vertical line is made of an upper part and lower part. If the print head is not properly positioned, the vertical line will be displayed as two disconnected lines, so that the line looks misaligned.

- If you still cannot determine the adjustment value, locate the square that is between adjacent squares whose lines form symmetry. Adjacent squares can be one or two places either side (at positions  $\pm 1$  or  $\pm 2$ ).

This illustration indicates an adjustment value that is set to "-1".

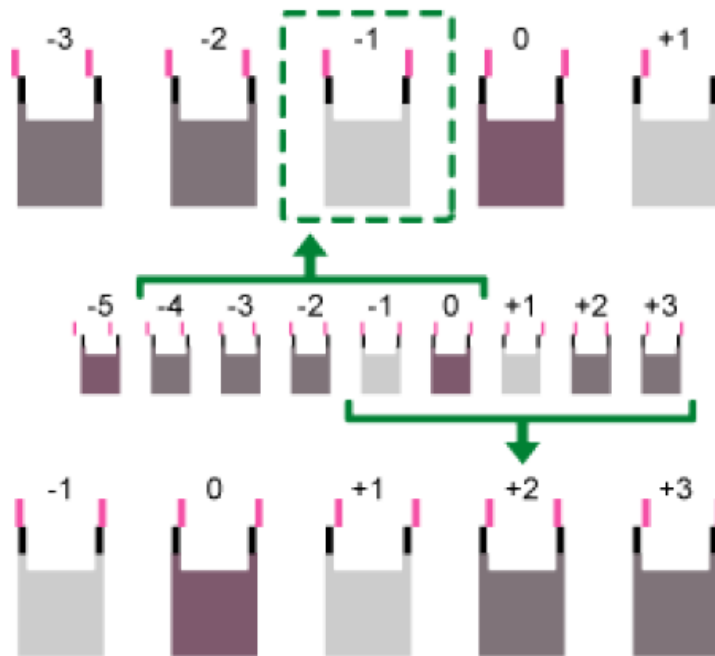

7. Press the [▲] or [▼]/Menu key to display [Adjustment] then press the [#Enter] key.

Head Position:  
Adjustment5

8. Press the [▲] or [▼]/Menu key to select the target's resolution from Step 5, then press the [# Enter] key.

Adjustment:  
High Speed

9. Select the items that you need to adjust, then press the [# Enter] key.

Adjustment:  
1.A

10. Enter the optimal adjustment values from Step 6, then press the [#Enter] key.

A:  
(-4, +4) 0

11. Press the [Escape] key.

## Adjust Paper Feed

If printed horizontal lines are misaligned, print images are patchy, or streaks are printed at regular intervals, print a test pattern, then adjust the paper feed setting.

### ★ Important

- Although instructions are provided, Sawgrass recommends that the procedure to adjust the paper feed be performed from the printer driver and not the printer control panel.

1. Press the [▼/Menu] key.

2. Press the [▲] or [▼/Menu] key to display [Maintenance], then press the [#Enter] key.

Menu:

Maintenance

3. Press the [▲] or [▼/Menu] key to display [Adj.Paper Feed], then press the [#Enter] key.

Maintenance:

Adj.Paper Feed

4. Press the [▲] or [▼/Menu] key to display [Pr.Test Pattern], then press the [#Enter] key.

Adj.Paper Feed:

Pr.Test Pattern

A test pattern to adjust paper feed is printed.

5. Check the optimal adjustment values on the printed test pattern.

The optimal adjustment value is the number that appears on the left of the lightest gray square with straight horizontal lines on both sides. When this number is "+2", the optimal adjustment value is "+2".

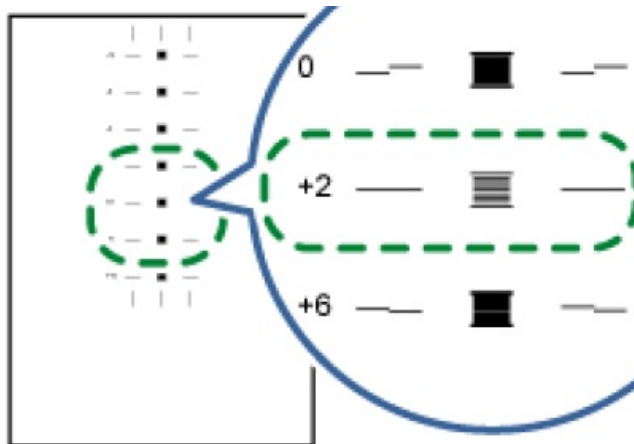

When horizontal lines beside the lightest gray square are broken, select the optimal adjustment value by referring to the lines broken in the opposite direction. When the "+2" square is the lightest gray square and the "+6" horizontal lines are broken in the opposite direction, the optimal adjustment value is between "+3" and "+5". After adjustment, check the adjustment result.

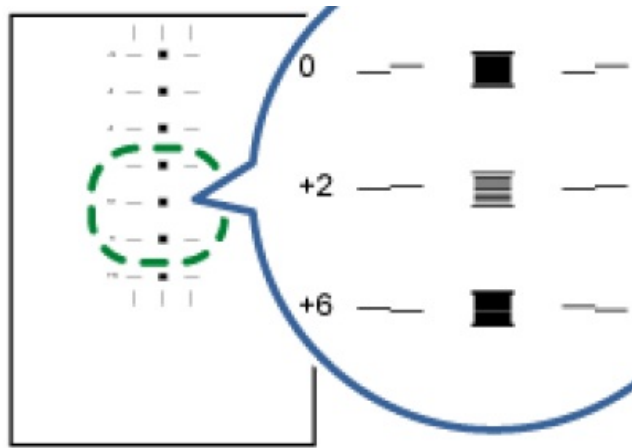

6. Press the [▲] or [▼/Menu] key to display [Adjustment], then press the [#Enter] key.

Adj.Paper

Feed: Adjustment

7. Press the [▲] or [▼/Menu] key to enter the adjustment value (-14 to +14) from Step 5, then press the [#Enter] key

Adjustment:

(-14, +14) 0

8. Press the [Escape] key.

#### Note

- If streaks still appear after the adjustment, continue to adjust the value by 1 and executing "Adjustment".
  - If black streaks appear, increase the adjustment value.
  - If white streaks appear, decrease the adjustment value.
- Keep adjusting the value and executing "Adjustment" until the black or white streaks disappear.

## Registration

Follow the procedure below to adjust where to start printing on paper loaded in each paper tray after checking the test pattern printed.

1. Press the [▼/Menu] key.

2. Press the [▲] or [▼/Menu] key to display [Maintenance], then press the [#Enter] key.

Menu:

Maintenance

3. Press the [▲] or [▼/Menu] key to display [Registration], then press the [#Enter] key.

Maintenance:

Registration

4. Press the [▲] or [▼/Menu] key to display [Pr.Test Pattern], then press the [#Enter] key.

Registration:

Pr.Test Pattern

5. Press the [▲] or [▼/Menu] key to select a paper tray, then press the [#Enter] key.

Pr.Test Pattern:

Tray 1

A test pattern to adjust the print start position is printed.

Check the optimal adjustment values on the printed test pattern.

**6. Fold the test pattern sheet in half lengthwise.**

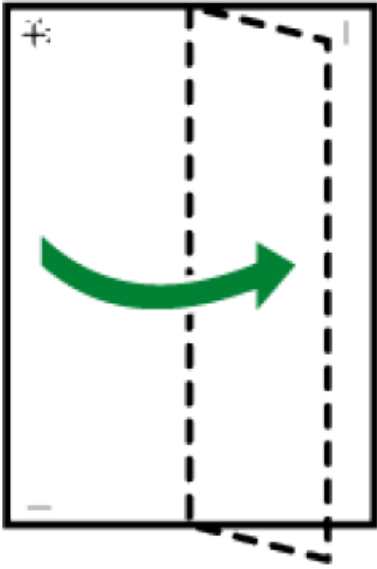

**7. The optimal adjustment value is the difference between the single vertical line and the cross's vertical line that you can see when the folded paper is held up to light. When the difference is one calibration mark in the "+" direction, the optimal adjustment value for the [Read Direction] is "+1.0".**

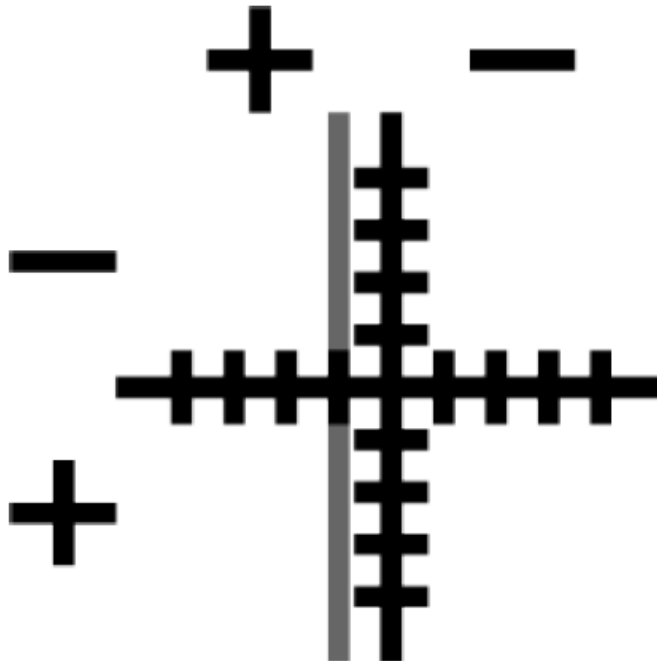

**8. Fold the test pattern sheet in half widthwise, then check the adjustment value for the [Feed Direction].**

Adjustment values are in 0.1 increments.

**9. Press the [▲] or [▼/Menu] key to display [Adjustment], then press the [#Enter] key.**

Registration:

Adjustment



10. Press the [▲] or [▼/Menu] key to select a paper tray, then press the [#Enter] key.

Adjustment:

Tray 1

11. Press the [▲] or [▼/Menu] key to enter the adjustment values (-4.0 to +4.0) in the [Read Direction] from Step 7, then press the [#Enter] key.

Read Direction:

(-4, +4) 0.0

12. Press the [▲] or [▼/Menu] key to enter the adjustment values (-4.0 to +4.0) in the [Feed Direction] from Step 8, then press the [#Enter] key.

Feed Direction:

(-4, +4) 0.0

13. Press the [Escape] key.

## Setting the Date and Time

Use the following procedure to specify the date, time, and time zone.

### Date setting

1. Press the [▼/Menu] key.

2. Press the [▲] or [▼/Menu] key to display [Maintenance], then press the [#Enter] key.

Menu:

Maintenance

3. Press the [▲] or [▼/Menu] key to display [Date/Time], then press the [#Enter] key.

Maintenance:

Date/Time

4. Press the [▲] or [▼/Menu] key to display [Date Setting], then press the [#Enter] key.

Date/Time:

Date Setting

5. Press the [▲] or [▼/Menu] key to set the date, then press the [#Enter] key.

 Region A (mainly Europe and Asia)

Date Setting:

30/ 8/2012

 Region B (mainly North America)

Date Setting:

8/30/2012

To specify the time next, go to Step 4 in section "Time Setting".

6. Press the [Escape] key.

### Time setting

1. Press the [▼/Menu] key.

2. Press the [▲] or [▼/Menu] key to display [Maintenance], then press the [#Enter] key.

Menu:  
Maintenance

**3. Press the [▲] or [▼/Menu] key to display [Date/Time], then press the [#Enter] key.**

Maintenance:  
Date/Time

**4. Press the [▲] or [▼/Menu] key to display [Time Setting], then press the [#Enter] key.**

Date/Time:  
Time Setting

**5. Press the [▲] or [▼/Menu] key to set the time, then press the [#Enter] key.**

 (mainly Europe and Asia)

Time Setting:  
10:31:25

 (mainly North America)

Time Setting:  
10:31:25 AM

To specify the time zone next, go to Step 4 in section "Time Zone Setting".

**6. Press the [Escape] key.**

### Time zone setting

**1. Press the [▼/Menu] key.**

**2. Press the [▲] or [▼/Menu] key to display [Maintenance], then press the [#Enter] key.**

Menu:  
Maintenance

**3. Press the [▲] or [▼/Menu] key display [Date/Time], then press the [#Enter] key.**

Maintenance:  
Date/Time

**4. Press the [▲] or [▼/Menu] key to display [Time Zone], then press the [#Enter] key.**

Date/Time:  
Time Zone

**5. Press the [▲] or [▼/Menu] key to set the time zone, then press the [#Enter] key.**

Time Zone:  
GMT+00:00

**6. Press the [Escape] key.**

### De-condensation

If the SC57000 error message appears, there might be condensation inside the printer. Dry the printer's interior by performing the de-condensation procedure. See page section "[Printer Errors](#)" for more information.

**1. Press the [▼/Menu] key.**

**2. Press the [▲] or [▼/Menu] key to display [Maintenance], then press the [#Enter] key.**

Menu:  
Maintenance

**3. Press the [▲] or [▼/Menu] key to display [De-condensation], then press the [#Enter] key.**

Maintenance:  
De-condensation

Three sheets are fed through the printer without anything being printed on them.

#### 4. Turn the printer off, then turn it on again.

If the error message does not reappear, the printer's interior has fully dried.

#### Note

- If the error persists, turn the printer off, leave it for an hour, and then turn it on again. If this does not resolve the problem, contact Sawgrass.

### Using the System Menu

#### Energy Saver

Use Energy Saver mode to reduce the printer's power consumption.

You can specify how long the printer remains idle before it switches to Energy Saver mode. When the printer is in Energy Saver mode, it requires time to start up when it receives a print job. You can specify between 5 and 60 minutes as the idle time before switching to the Energy Saver mode.

Default: **[5 minutes] Notify by Email**

You can specify whether or not to send notification that a printer error has occurred to a particular e-mail address.

Use the Web browser to specify e-mail address to send notification. See section "[Notifying the Printer Status by E-mail](#)".

Default: **[Off]**

#### Memory Usage

Insufficient memory can cause printing to fail or a file's image data to not be printed. If this happens, you can specify the priority assigned to the printer's memory space.

Select [Font Priority] if a file's image data is not printed. Select [Frame Priority] if printing fails due to insufficient memory.

Default: **[Frame Priority] Unit of Measure**

You can switch the measurement between "mm" and "inch".

 **Region A** (mainly Europe and Asia)

Default: **[mm]**

 **Region B** (mainly North America) Default: **[inch]**

#### Page Size

You can select the default paper size.

 **Region A** (mainly Europe and Asia) Default: **[A4 (210 × 297)]**

 **Region B** (mainly North America) Default: **[8 1/2 × 11]**

#### Ink C.U. Space

You can check the remaining capacity of the waste collection unit.

### Changing the [System] Menu

The following procedure is an example of setting the Energy Saver mode.

1. Press the [**▼** /Menu] key.

2. Press the [**▲**] or [**▼** /Menu] key to display [System], then press the [#Enter] key.

Menu:

System

3. Press the [**▲**] or [**▼** /Menu] key to display [Energy Saver], then press the [#Enter] key.

System:

Energy Saver

4. Press the [#Enter] key.

5. Press the [**▲**] or [**▼** /Menu] key to select the lead time needed to switch to the Energy Saver mode.

E.Saver Timer:  
\*5 minutes

**6. Press the [#Enter] key.**

**7. Press the [Escape] key.**

## Using the [Host Interface] Menu

In the [Host Interface] menu, you can specify settings related to connection and communication. Settings made using the [Host Interface] menu remain effective even if you turn the printer off.

To configure the printer's network settings, use the [Network Setup] menu.

### I/O Timeout

Specify how long the printer waits for the currently-connected interface to respond. When the specified time elapses, the printer can receive data from another interface.

If you make the I/O Timeout period too short, timeout might occur while data transfer is in progress. If this happens, the print job will be interrupted by a new job from another interface.

You can specify a timeout between 10 and 60 seconds. Default: [15 seconds]

### Network Setup

You can make network-related settings.

#### Printer Name

Displays the printer's name.

#### Host Name

Displays the printer's host name.

#### Domain Name

Displays the printer's domain name.

#### IPv4 DNS

Specify the DNS server settings under IPv4.

If DHCP is off, enter the IPv4 addresses for the primary and secondary DNS servers in the format "xxx.xxx.xxx.xxx" (where each x represents a digit).

Default: [0.0.0.0]

#### IPv4 DDNS

Specify the setting to update the host or domain name. Default: [On]

#### DHCP

You can specify whether or not to use DHCP in an IPv4 environment. Default: [ On]

#### IPv4 Address

You can specify the printer's IPv4 address.

When DHCP is set to on, the IP address cannot be changed. To change it, set DHCP to off.

Contact your network administrator for information about the network configuration. Default: [11.22.33.44]

#### IPv4 Subnet M.

You can specify the subnet mask.

When DHCP is set to on, the subnet mask cannot be changed. To change it, set DHCP to off. Contact your network administrator for information about the network configuration.

Default: [0.0.0.0]

#### IPv4 Gateway.Ad.

You can specify the IPv4 gateway address.

When DHCP is set to on, the gateway address cannot be changed. To change it, set DHCP to off. Contact your network administrator for information about the network configuration.

Default: [0.0.0.0]

#### IPv6 DDNS

Specify the setting to update the host or domain name. Default: [On]

#### IPv6 DNS

Specify the DNS server settings under IPv6.

If DHCP is off, enter the IPv6 addresses for the primary and secondary DNS servers in the form "xxxx:xxxx:xxxx:xxxx:xxxx:xxxx:xxxx:xxxx" (where each x represents a digit).

Default: [::]

#### DHCPv6

You can specify whether or not to use DHCP in an IPv6 environment.

Default: [Off]

#### IPv6 Statlss Ad

Select whether to enable or disable IPv6 stateless address auto configuration. Default: [On]

#### IPv6 Address

You can specify the printer's IPv6 address.

#### IPv6 Gateway.Ad.

You can specify the IPv6 gateway address. Default: [::]

#### **Active Protocol**

Select the protocol by setting the IPv4, IPv6, HTTP (IPv4), HTTP (IPv6), and Web protocols to [Active] or [Not Active].

Default: [Active]

#### **IPsec**

Specify the printer's IPsec function Active/Not Active. Default: [Off]

#### **MAC Address**

Displays the printer's MAC address (physical address).

#### **Ethernet Speed**

Set the access speed for networks.

Select a speed that matches your network environment. [Auto Select] should usually be selected.

Default: [Auto Select] **Prmt SNMPv3 Com**

Select SNMPv3 communication for managing the printer using MIB. Default: [Ciphertext]

#### **Pmt SSL/TLS Com**

Set SSL/TLS communication under IPv4 and IPv6 to [Active] or [Not Active]. This communication mode will be used when you specify printer settings using a Web browser.

Default: [Active]

#### **Restore Default**

*You can reset the network settings to their defaults.  
You can display the wireless LAN's MAC address (physical address).*

### **USB Setting**

You can specify the settings related to communication when the computer and printer

are connected via USB. Usually, you do not need to change these settings. After changing this setting, turn the printer off, then turn it on again.

#### **USB Speed**

Default: [Auto]

#### **Port Setting**

Default: [Off]

## **Changing the [Host Interface] Menu**

This section gives an example of changing a setting in the [Host Interface] menu.

1. Press the [▼/Menu] key.

2. Press the [▲] or [▼/Menu] key to display [Host Interface], then press the [#Enter] key.

Menu:

Host Interface

3. Press the [▲] or [▼/Menu] key to display [I/O Timeout], then press the [#Enter] key.

Host Interface:

I/O Timeout

4. Press the [▲] or [▼/Menu] key to display [20 seconds], then press the [#Enter] key.

I/O Timeout:

20 seconds

5. Press the [Escape] key.

## **Precautions When Using a Networked Printer**

### **Using DHCP**

- You can register the host name to a DNS server. In the Web Image Monitor menu, you can enable or disable [Notify Host Name to DHCP Server]. For details, see section "Changing the Printer Settings" for more information.
- The DHCP Relay Agent is not supported.
- Supported DHCP server operating systems are: Windows Server 2003/2003 R2, Windows Server 2008, and UNIX standard.

- The IP address acquired from DHCP can be checked on the configuration page. For details about printing a configuration page, see section "Using the [List/Test Print] Menu".
- When there are multiple DHCP servers, make the same configuration for all. This printer uses information from the DHCP server that responds first.

## Using the [Language] Menu

This section explains how to select the language used for the settings and messages displayed on the display.

**1 Press the [▼ /Menu] key.**

**2. Press the [ ] key once, then press the [#Enter] key.**

Menu:

Language

**3. Press the [▲] or [▼ /Menu] key key to select the language, then press the [#Enter] key.**

Language:

\*English

On the display, the names of the available languages appear in English. The message "Power Off On to Change Setting" appears.

**4. Turn the printer off then turn it on again.**

## Software

This chapter describes system and design software requirements and how to acquire, install and configure printer driver and color management software.

## System Requirements

The printer may be used with both Windows and Macintosh operating systems that meet recommended system specifications.

### ★ Important

Sawgrass may limit support to customers who use less than the minimum stated requirements.

Problems may occur if the computer does not meet recommended system requirements

- Print speeds may be longer and therefore less economical to run.
- Larger graphic files may not print properly or at all.
- The computer may get 'hung up' or 'time out' during the processing of the print command.
- Graphic design programs may be much slower to use.
- Print spooling may not work properly because of lack of computer or printer memory capacity.
- Graphics may not print correctly.
- Images may be cut off.
- Longer print times can lead to nozzle drops or banding.

### Windows\* with PowerDriver or Creative Studio

### Macintosh with MacProfile or Creative Studio

Windows OS versions 7, 8, or 10

Macintosh OS 10.6 or later (MacProfile)

Minimum RAM: 2GB

Macintosh OS 10.9 or later (CreativeStudio)

Recommended RAM: 4GB

Minimum RAM: 2GB

Recommended CPU: Dual Core 2 GHz

Recommended RAM: 4GB

\*Only Professional, Business, Enterprise and Ultimate Editions have been tested and approved.

### CreativeStudio Browser Recommendation

CreativeStudio is compatible with most widely-available internet browsers. However, Sawgrass strongly recommends using Google Chrome.

### Internet Connection Speed Requirements

Minimum Download Speed: 5mbps  
 Minimum Upload Speed: 2mbps  
 Recommended Download Speed: 10mbps or higher  
 Recommended Upload Speed: 5mbps or higher

## Design Software Requirements

Certain types of design software are required for high quality prints and correct color output. Sawgrass may limit support to customers who do not use the specified software.

### Important

Poor print and color quality will likely occur if specified software is not used.

#### Windows\*

#### Macintosh

CorelDRAW 12 – X8

Adobe PhotoShop CS – CS6

Adobe PhotoShop CS – CS6

Adobe Illustrator CS – CS6

Adobe Illustrator CS – CS6

Adobe Creative Cloud (“CC”)

Adobe Creative Cloud (“CC”)

Adobe PhotoShop Elements 8-10 & 12-14

Adobe PhotoShop Elements 8-10 & 12-14

\*Specific versions may only be supported on Windows 7, 8 or 10.

## Download, Install and Configure Software

Download the printer software and related instructions from [sawgrassink.com](http://sawgrassink.com).

- If the computer to be used with the printer is not connected to the internet, download what is needed from another computer that has internet access.
- Using the USB drive supplied with the printer, transfer the files to the computer without internet access.
- Alternatively, contact an authorized Sawgrass distributor for assistance.



## Monitoring and Configuring the Printer

This chapter describes how to monitor and configure the printer.

### Using Web Image Monitor

The following operations can be remotely performed using Web Image Monitor from a client computer.

- Displaying printer status or settings
- Making printer settings
- Making e-mail notification settings
- Making network protocol settings
- Performing maintenance
- Making security settings
- Resetting the printer
- Updating the printer's firmware

### Configuring the printer

To perform the operations from Web Image Monitor, TCP/IP is required. After the printer is configured to use TCP/IP, operations from Web Image Monitor become available.

### Recommended Web browsers

- Windows:

Internet Explorer 6.0 or higher Firefox 2.0 or higher

Google Chrome 2.0 or higher

- Mac OS:

Safari 2.0 or higher Firefox 2.0 or higher

Google Chrome 2.0 or higher

- If the previous versions of the Web browser above are used or JavaScript and cookies are not enabled with the Web browser used, display and operation problems may occur.
- Non-recommended Web browsers might not display certain screen elements correctly.
- If you are using a proxy server, change the Web browser settings. Contact your network administrator for information about the settings.
- The previous page may not appear even after the back button of a Web browser is clicked. If this happens, click the refresh button of a Web browser.

### Displaying Top Page

This section explains the Top Page and how to display Web Image Monitor.

#### 1. Launch the Web browser.

#### 2. In the address bar, enter "**http://(printer's IP address or host name)/**".

*When setting SSL, a protocol for encrypted communication, under environment which server authentication is issued, enter "**https://(printer's IP address or host name)/**".*

The displayed Web Image Monitor page is split into the following areas:

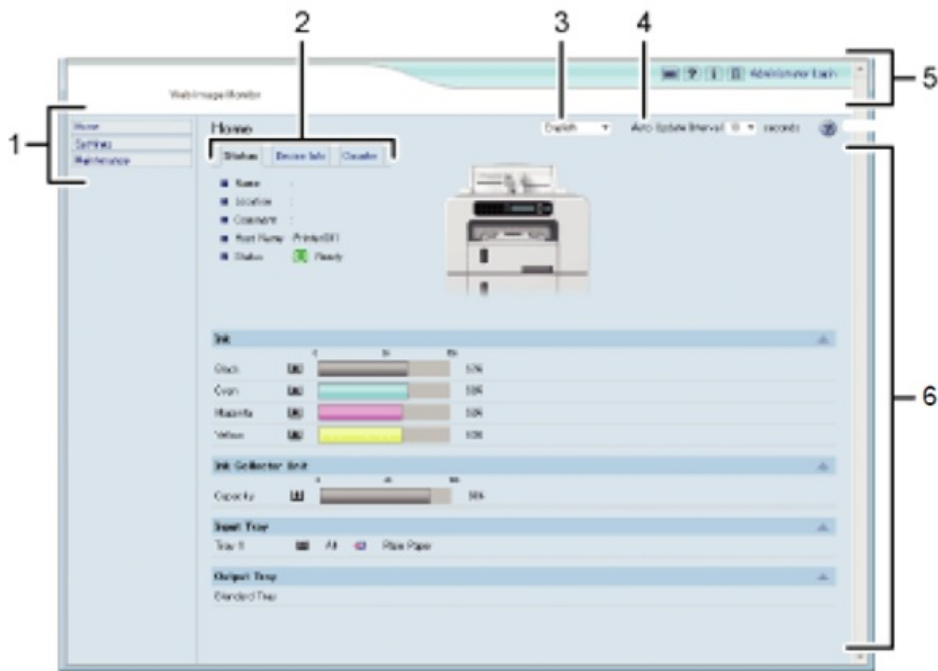

### 1. Menu Area

A menu to access Home, Settings and Maintenance.

### 2. Tab area

Details about each menu will display in each tab.

### 3. Language Selection Menu

Select a language.

If the displayed page is garbled when using an English language operating system, select "English" with the language selection menu.

### 4. Auto Update Interval

Specify the update interval for information on the [Status] tab.

Information for other menus and tabs are not automatically updated, so click [Refresh] to update.

Default: [10 seconds]

### 5. Header area

Check the version of the printer's firmware by clicking . Sawgrass may periodically provide updates to the printer's firmware. Change the printer settings by clicking [Administrator Login] to access the printer as an administrator.

### 6. Main Area

Displays the contents of the item selected in the menu area.

#### Note

- To display Web Image Monitor, click [Web Image Monitor...] on the [Configuration/About] tab in the [Printing Preferences] dialog box.

## Menu

This section explains the items in the Web browser menu.

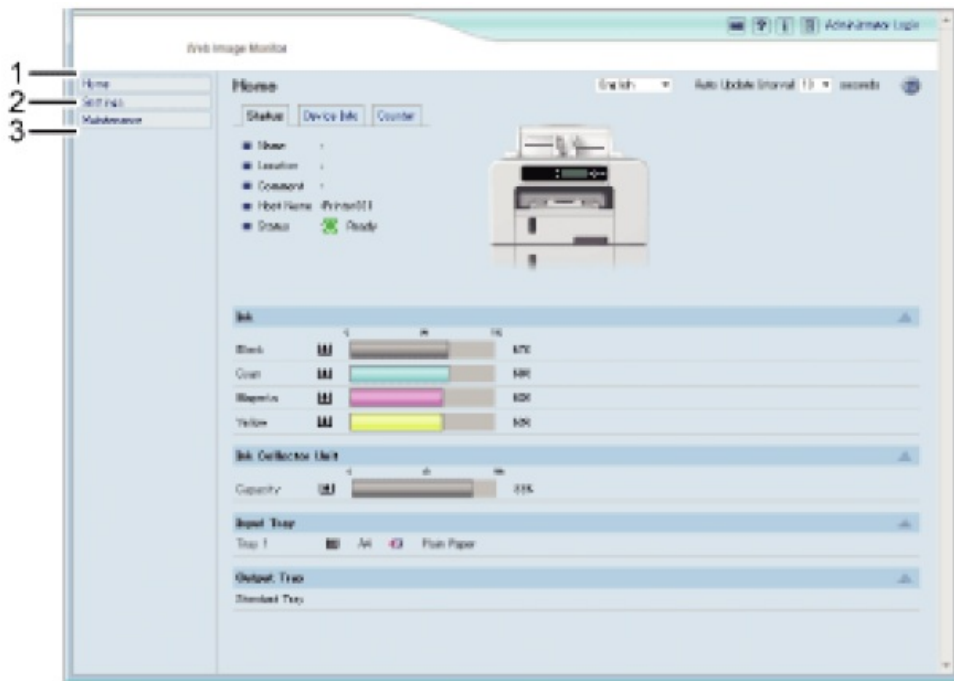

### 1. Home

The [Status], [Device Info], and [Counter] tab are displayed. Details of the tab menu are displayed on the work area.

### 2. Settings

Make system settings for the printer, interface settings, and security.

### 3. Maintenance

Click to perform printer maintenance.

## Logging in Using Web Image Monitor

To change the printer settings, log in to the printer as the administrator.

### 1. Launch the Web browser.

2. In the address bar, enter "http://(printer's IP address or host name)".

3. Click [Administrator Login].

A dialog box for entering the user name and password opens.

4. Enter the user name and password, then click [OK].

If this is the first time to do this, enter "admin" as the user name and leave the password blank.

To ensure security, it is important you change the password.

5. In the menu area, click [Settings].

6. Specify the printer settings.

7. Click [OK].

The specified settings are transmitted to the printer.

## Changing the Printer Settings

You can specify the following settings on each page of Web Image Monitor.

[Device Settings] area

- [System] page

You can specify [Device Name], [Comment], [Location], and [Recycle Paper Mode].

- [Date/Time] page

You can specify [Set Date], [Set Time], [SNTP Server Address], [SNTP Polling Interval], [Time Zone], and [Daylight saving time settings].

- [Email] page

For details about the items and descriptions, see section "[Notifying the Printer Status by E-mail](#)".

- [ROM Update] page

You can check the printer's firmware version Sawgrass may periodically provide updates to the printer's firmware.

## **[Auto Email Notification] area**

| *See section "[Notifying the Printer Status by E-mail](#)".*

## **[Administrator Tools] area**

- [Administrator Authentication] page

You can specify [New Password] and [Confirm New Password].

- [Restore Defaults] page

You can restore the default settings for the network interface.

## **[Interface] area**

- [Interface Settings] page
  - [Ethernet]

You can specify [Ethernet Speed].

## **[Network] area**

- [IPv4] page

You can specify whether to enable or disable [IPv4].

- [Ethernet + Wireless LAN]

You can specify [Host Name], [DHCP], [Notify Host Name to DHCP Server], [Domain Name], [Use Domain Name], [IPv4 Address], [Subnet Mask], and [AutoIP].

- [Details]

You can specify [Default Gateway Address], [DNS Server1], [DNS Server2], [DNS Protocol Priority], [LPR(515)], [DIPRINT(9100)], [IPP(80/631)], [WSD

(Device)], [WSD (Device) Port Number], [WSD (Printer)], [WSD (Printer) Port Number], [WSD (Printer) / IPP Timeout], and [LLTD].

- [IPv6] page

You can specify whether to enable or disable [IPv6].

- [Ethernet + Wireless LAN]

You can specify [Host Name], [Domain Name], and [Manual Configuration Address].

- [Details]

You can specify [Default Gateway Address], [DNS Server1], [DNS Server2], [DNS Protocol Priority], [LPR(515)], [DIPRINT(9100)], [IPP(80/631)], [WSD

[Device]), [WSD (Device) Port Number], [WSD (Printer)], [WSD (Printer) Port Number], [WSD (Printer) / IPP Timeout], and [LLTD].

- [DHCPv6] page

You can specify [DHCPv6 Operation Mode], [IAID], and [Request Timeout].

- [DDNS] page

You can specify [IPv4], [IPv6], [A Record Registration for DHCP], [AAAA Record Registration for DHCPv6], [Operation when records are duplicated], and [Interval to Update Device's Record].

- [SNMP] page
  - [Protocol]

You can specify whether to enable or disable IPv4 and IPv6 when using [SNMP(161)].

- [SNMPv1,v2 Setting]

You can specify [SNMPv1,v2 Function], [SNMPv1 Trap Communication], and [SNMPv2 Trap Communication].

- [Community]

You can configure up to four SNMP communities.

- [SNMPv3] page
  - [SNMPv3 Setting]

You can specify [SNMPv3 Function], [SNMPv3 Trap Communication], and [Permit SNMPv3 Communication].

- [Permit SNMPv3 Communication]

You can configure up to five SNMPv3 trap destinations.

- [Account(User)]

You can specify [Account Name(User)], [Authentication Password(User)], [Authentication Password re-enter(User)], [Encryption Password(User)], [Encryption Password re-enter(User)], and [Access Type(User)].

- [Account(Administrator)]

You can specify [Account Name(Administrator)], [Authentication Password(Administrator)], [Authentication Password re-enter(Administrator)], [Encryption Password(Administrator)], [Encryption Password re-enter(Administrator)], and [Access Type(Administrator)].

- [Bonjour] page

You can specify whether to enable or disable IPv4 and IPv6 when using [Bonjour].

- [Details]

You can specify [Computer Name] and [Location].

- [Print Order Priority]

You can specify [DIPRINT], [LPR], and [IPP].

## **[Security] area**

- **[Network Security] page**
  - [SSL/TLS Version]

You can specify [TLS1.1], [TLS1.0], and [SSL3.0].

- **[Encrypted Communication Settings]**

You can specify [AES], [3DES], and [RC4].

- **[Access Control] page**
  - [IPv4]

You can configure up to five access control ranges.

- **[IPv6]**

You can configure up to five [Range] and [Mask] settings.

- **[IPP Authentication] page**

You can configure up to ten [Authentication], [User Name], and [Password] settings.

- **[SSL/TLS] page**

You can specify [SSL/TLS(443)] and [Permit SSL/TLS Communication].

- **[Site Certificate] page**

- [Imported Site Certificate]

You can select [Delete] or [Update to Trustworthy Certificate] for an imported site certificate.

- **[Site Certificate to Import]**

Import the site certificate according to the displayed instructions.

- **[Device Certificate] page**

You can select [Create], [Request], [Install], [Install intermediate Certificate], [Delete/Cancel Request], and [Delete intermediate Certificate] for up to three certificates.

- **[Certification]**

Select the certificate to be used in [SSL/TLS], [Wireless LAN], and [IPsec].

- **[IPsec] page**

You can specify [IPsec].

You can configure up to ten parameters.

## Notifying the Printer Status by E-mail

You can be notified of the printer status by e-mail on an occasion such as if the printer runs out of paper or paper is jammed.

The e-mail notifying the printer status will be sent to the e-mail address specified as the destination in advance. You can also specify the timing and status to notify.



- Depending on your e-mail application, a phishing warning message might appear when you receive e-mail. To stop this warning message, see your e-mail application's Help for details about registering trusted senders.

To receive reports of the printer's status by e-mail, set [Notify by Email] to [On] in the [System] menu, then specify an e-mail address and other required settings using Web Image Monitor. The [Auto Email Notification] setting can be changed only by the administrator.

The following status can be notified:

- The printer error has occurred.
- The ink has run out.
- The ink will run out soon.
- The Waste Collection Unit must be replaced now.
- The Waste Collection Unit must be replaced soon.
- The paper has run out.
- The paper has jammed.
- The paper type is wrong.
- The paper size is wrong.

- The paper size and type are wrong.
- A cover is open.
- The specified part such as paper tray is not attached correctly.
- The printer is out of its operational temperature range.
- The total number of printed pages.

#### Note

- For details about Notify by Email, see section "[Using the \[System\] Menu](#)".
- How to log in as the administrator, see section "[Logging in Using Web Image Monitor](#)".

## Specifying notification the printer status by e-mail

On the [Email] page, you can specify the basic and authentication settings for sending e-mail.

You can enable or disable Auto Email Notification. The "Administrator Email Address" will appear in the e-mail message. The "Device Email Address" will appear in the "From" box. **[Auto Email Notification]**

You can specify whether to enable or disable this function. Default: **[Inactive]**

### **[Device Email Address]**

Enter the device's e-mail address using up to 127 characters.

Default: Blank

### **[Administrator Email Address]**

Enter the administrator's e-mail address using up to 127 characters.

Default: Blank

### **[Email Body]**

Enter messages using up to 255 characters.

Default: Blank

### **[SMTP]**

You can specify the SMTP server name and SMTP Port No. By specifying the SMTP authentication setting, you can send e-mails to destinations where the e-mail server carries out SMTP authentication.

By specifying the SMTP authentication setting, you can log on to SMTP servers which require authentication. The supported authentication protocols are: CRAM MD5, PLAIN, and LOGIN.

- [SMTP Server Name]

| *Enter the server name using up to 127 characters. Default: Blank*

- [SMTP Port No.] Default: **[25]**
- [SMTP AUTH]

You can specify whether to enable or disable this function. Default: **[Inactive]**

- [SMTP Auth. User Name]

Enter the user name using up to 191 characters. Default: Blank

- [SMTP Auth. Password]



Enter the password using up to 63 characters. Default: Blank

- [Confirm SMTP Auth. Password]

Enter the password using up to 63 characters. Default: Blank

- [SMTP Auth. Encryption]

If you select [Auto Select], the printer logs on using DIGEST MD5, CRAM MD5, NTLM Authentication, LOGIN, then PLAIN.

If you select [On], the printer logs on using DIGEST MD5, CRAM MD5, then NTLM Authentication.

If you select [Off], the printer logs on using LOGIN and then PLAIN. Default: [**Auto Select**]

#### [POP before SMTP]

By specifying the SMTP authentication setting, you can send e-mails to destinations where the e-mail server carries out SMTP authentication.

By using POP before SMTP, you can log on to an SMTP server supporting POP before SMTP.

You can specify whether to use POP before SMTP, and specify the POP server name, POP port number, POP user name, and POP password.

- [POP before SMTP]

| *You can specify whether to enable or disable this function.*

Default: [**Inactive**]

- [POP User Name]

Enter a user name using up to 127 characters. Default: Blank

- [POP Password]

Enter a password using up to 63 characters. Default: Blank

- [Confirm POP Password]

Enter a password using up to 63 characters. Default: Blank

- [POP Auth. Encryption]

If you select [Auto Select], the printer logs on by APOP login, then in plain text. If you select [On], the printer logs on only by APOP login.

If you select [Off], the printer logs on only in plain text. Default: [**Auto Select**]

- [Timeout setting after POP Auth.]

In standby time following POP authentication (in milliseconds), you can specify how long the printer can wait for logging on to the SMTP server after logging on to the POP server.

Default: [**300 milli-second**] [**POP3/IMAP4**]

- [POP Server Name]

Enter the server name using up to 127 characters.

Default: Blank

[Email Reception Port]

- [POP3 Reception Port No.] Default: [**110**]

### Auto Email Notification: Error Notification by Email: Group 1-3

#### [Groups to Notify]

[Back to the top](#)

- [Group Name]

Enter a group name using up to 19 characters. Default: Blank

- [Email Language]

You can select the language used for e-mail. Default: [**English**]

- [Subject]

Enter a subject using up to 31 characters. Default: Blank

- **[Message]**

Enter a message using up to 255 characters. Default: Blank

### **[Notify]**

- [Notify 1-5]

Enter up to 19 characters for [Name] and up to 127 characters for [Email Address].

Default: Blank

### **[Error Items to Notify]**

Select which errors are sent as e-mail notifications.

- [Error: Printer]
- [Out of Ink]
- [Low Ink]
- [Replace Waste Collection Unit]
- [Prepare new Waste Collection Unit]
- [Out of Paper]
- [Paper Misfeed]
- [Paper Size Error]
- [Paper Type Error]
- [Paper Size/Paper Type Error]
- [Cover Open]
- [Unit/Cartridge Not Set]
- [Device cannot be used in this temperature conditions.] Default: Not selected

## **Auto Email Notification: Counter Notification: Group**

### **[Groups to Notify]**

- [Email Language]

You can select the language used for e-mail. Default: **[English]**

- [Subject]

Enter a subject using up to 31 characters. Default: Blank

### **[Notify]**

- [Notify 1-5]

Enter up to 19 characters for [Name] and up to 127 characters for [Email Address].

Default: Blank

### **[Notification Item]**

- [Total Pages Printed] Default: Not selected

## **Auto Email Notification: Detailed Settings for Error Notification**

### **[Error: Printer]**

- [Notify when error:] Default: **[Occurs]**
- [Notify within:] Default: **[5 minute(s)]**

#### **[Out of Ink]**

- [Notify when error:] Default: **[Occurs]**
- [Notify within:] Default: **[5 minute(s)]**

#### **[Low Ink]**

- [Notify when error:] Default: **[Occurs]**
- [Remaining] Default: **[10%]**

#### **[Replace Ink Collector Unit]**

- [Notify when error:] Default: **[Occurs]**
- [Notify within:] Default: **[5 minute(s)]**

#### **[Prepare new Ink Collector Unit]**

- [Notify when error:] Default: **[Occurs]**
- [Remaining] Default: **[10%]**

#### **[Out of Paper]**

- [Notify when error:]

Default: **[Occurs]**

- [Notify within:] Default: **[5 minute(s)]**

#### **[Paper Misfeed]**

- [Notify when error:] Default: **[Occurs]**
- [Notify within:] Default: **[5 minute(s)]**

#### **[Paper Size Error]**

- [Notify when error:] Default: **[Occurs]**
- [Notify within:] Default: **[5 minute(s)]**

#### **[Paper Type Error]**

- [Notify when error:] Default: **[Occurs]**
- [Notify within:] Default: **[5 minute(s)]**

#### **[Paper Size/Paper Type Error]**

- [Notify when error:] Default: **[Occurs]**
- [Notify within:] Default: **[5 minute(s)]**

#### **[Cover Open]**

- [Notify when error:] Default: [**Occurs**]
- [Notify within:] Default: [**5 minute(s)**]

### **[Unit/Cartridge Not Set]**

- [Notify when error:] Default: [**Occurs**]
- [Notify within:] Default: [**5 minute(s)**]

### **[Device cannot be used in this temperature conditions.]**

- [Notify when error:] Default: [**Occurs**]
- [Notify within:] Default: [**5 minute(s)**]

## **Auto Email Notification: Counter Notification**

### **[Total Pages Printed]**

- [Method to Notify]

Default: [**Number of Pages**]

- [Interval]

Default: [**100 Per Page**]

- [Date to Notify] Default: [**1**]

## **Maintenance**

**This chapter describes how to maintain the printer.**

### **Ink Cartridges**

#### **Checking the Remaining Ink**

Follow the procedure below to check when to replace ink cartridges using the Web Image Monitor or the cartridge replacement indicators.

#### **Checking the remaining ink level on the display**

You can check the remaining ink level by looking at the icon that appears above the cartridge replacement indicator.

K, C, M, and Y indicate black, cyan, magenta, and yellow, respectively.

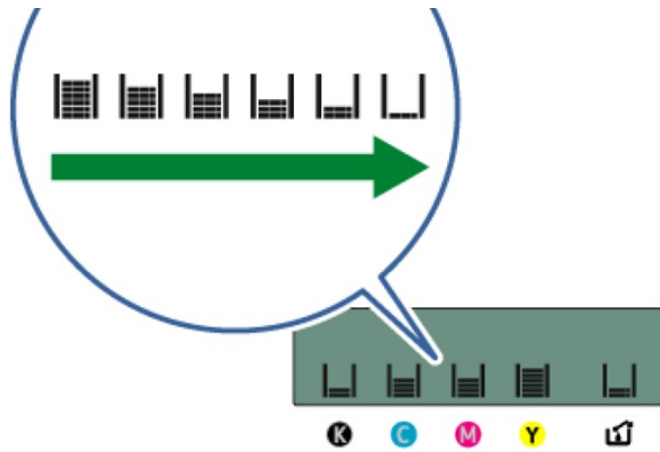

If the ink will soon run out, the message "Low Ink" appears on the display. Make sure you have a new ink cartridge for the color indicated by the icon.

If an ink cartridge runs out of ink, the message "Open Front Cover / Replace Ink Crtg" appears on the display.

Replace the ink cartridge indicated by the or icon.

### Checking the remaining ink level on the Web Image Monitor

The Web Image Monitor can be used to check ink levels.

See section "Using Web Image Monitor" for more information.

### Checking the remaining ink level via PowerDriver

PowerDriver on Windows OS can also be used to check ink levels. See [sawgrassink.com](http://sawgrassink.com) for more information.

### Replacing an Ink Cartridge

Clear any errors, such as when there is a paper jam or when no paper is loaded, before replacing an ink cartridge.

- When removing the ink cartridge, do not touch the inside of the printer.
- Carefully install an ink cartridge in the correct position.

**1. Take the ink cartridge out of the box.**

**2. Open the right front cover.**



**3. Take out the empty cartridges.**

| While taking out the cartridges, be sure to hold the printer firmly so that it does not move.

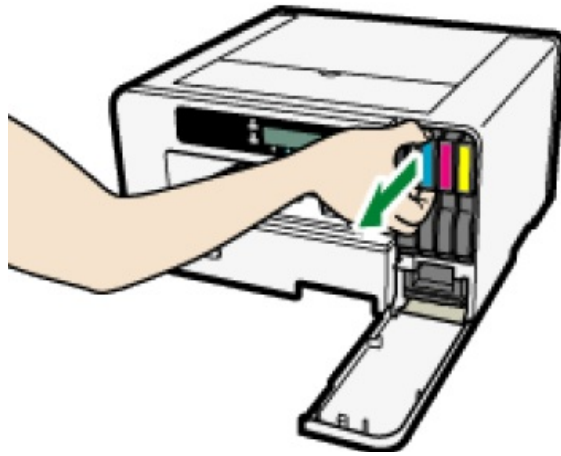

**4. Check the cartridges' orientation, then install them carefully.**

| Install in the following order from the left: black, cyan, magenta, and yellow.

**5. Push each cartridge fully in.**

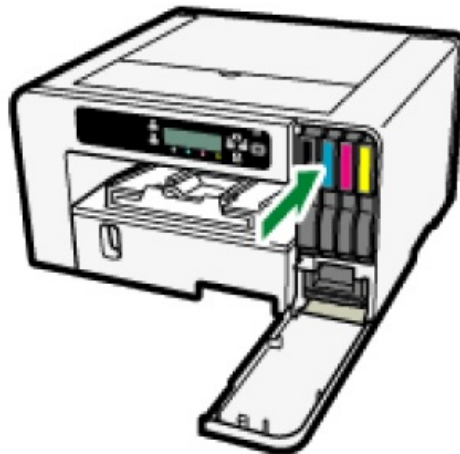

**6. Close the right front cover.**

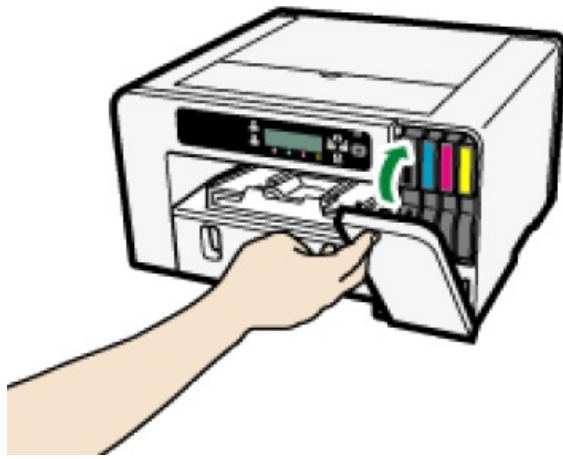

## Handling Ink Cartridges

### ! Warning:

- The following explains the warning messages on the plastic bag used in this product's packaging.
- Keep the polythene materials (bags, gloves, etc.) supplied with this printer away from babies and small children at all times. Suffocation can result if polythene materials are brought into contact with the mouth or nose.

### ! Caution:

- Keep ink and ink containers out of reach of children.
- If ink gets into contact with eyes, flush eyes with clean, lukewarm water (low pressure) for at least 15 minutes, occasionally lifting eyelids to ensure that the chemical is being flushed out of the eyes. Obtain medical attention.
- If ink is ingested, wash out mouth with water provided person is conscious. Consult a doctor immediately.
- When removing jammed paper or replacing ink, avoid getting ink on your clothing. If ink comes into contact with your clothing, refer to the ink cartridge labeling for recommended procedures.
- When removing jammed paper or replacing ink, avoid getting ink on your skin. If ink comes into contact with your skin, wash the affected area thoroughly with soap and water. If irritation develops, seek medical attention.
- When removing the ink cartridge, avoid putting your hand near the place where the ink cartridge is installed. If ink comes in contact with your hands, wash them thoroughly with soap and water. If irritation develops, seek medical attention.

## About ink cartridges

- Ink cartridges comply with the Sawgrass safety specifications. To ensure safety and reliability, use genuine Sawgrass ink cartridges.
- Do not reuse the Sawgrass ink cartridges.

## Using ink cartridges

- Ink cartridges should be used up before their "Recommended Use by Date", ideally within six months of being removed from their packaging.
- Do not open the package of an ink cartridge until the cartridge will be installed in the printer.
- Do not touch the cartridge's ink inlets or chip contacts.
- Do not shake ink cartridges strongly. Ink may leak out.
- Do not take apart ink cartridges.
- Do not turn off the power or unplug the power cord during the process of installing the cartridges.
- Always confirm the color of an ink cartridge before installing it.
- Do not remove an ink cartridge while printing is being performed. Printing will stop.

## Storing ink cartridges

- Store ink cartridges at a temperature between 15°C and 25°C (59°F to 77°F), relative humidity above 35% without condensation.

## Ink consumption

- To protect the print head and ensure print quality, the printer performs periodic maintenance and print head cleaning when it is turned on. Both operations consume ink.
- If you intend not been use the printer for a period of time, see section "
- [When Not Using for a Long Period of Time](#)" for precautionary information.

## Waste Collection Unit

### Checking the Waste Ink Level

Follow the procedure below to check when to replace a waste collection unit using the Web Image Monitor or the waste ink full indicator.

### Checking the waste ink level on the display

You can check the waste ink level by looking at the icon that appears above the waste ink full indicator.

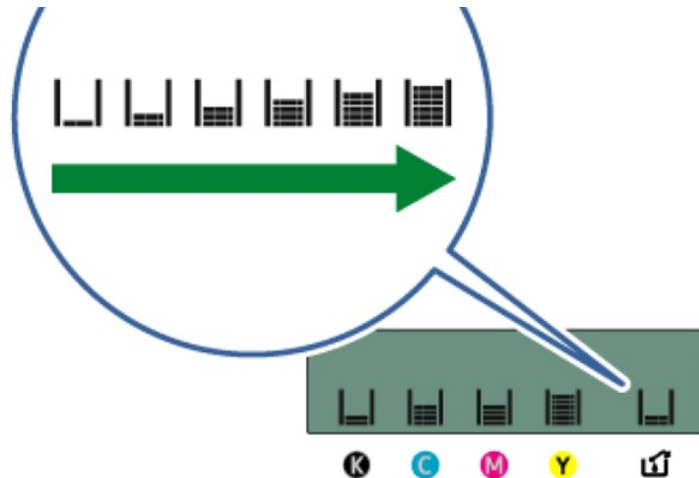

If the waste collection unit is almost full, the message "[Prepare new Waste Collection Unit](#)" appears on the display.

Make sure you have a new waste collection unit on hand.

If the waste collection unit is full, the message "Waste Collection Unit is full / Replace Waste Collection Unit" appears on the display.

Replace the waste collection unit.

### Checking the waste ink level on the Web Image Monitor

The Web Image Monitor can be used to check ink levels.

See section "[Using Web Image Monitor](#)" for more information.

### Checking the waste ink level via PowerDriver

PowerDriver on Windows OS can also be used to check ink levels. See [sawgrassink.com](http://sawgrassink.com) for more information.

## Replacing a Waste Collection Unit

! Warning:

- The following explains the warning messages on the plastic bag used in this product's packaging.



- **Keep the polythene materials (bags, gloves, etc.) supplied with this printer away from babies and small children at all times.** Suffocation can result if polythene materials are brought into contact with the mouth or nose.

- Do not use a waste collection unit that has not been used for a long time.
- Do not touch the waste collection unit's chip contacts.
- Take care not to drop the waste collection unit.
- Take care not to drop the waste collection unit when putting it in the supplied plastic bag. The bag might tear, causing ink to spill.
- Make sure the waste collection unit is fully inserted. If it is not, an error may occur or ink will leak inside the printer.

**1. Take the waste collection unit out of the box.**

**2. Open the right front cover.**



**3. Wait at least five seconds, then remove the waste collection unit from the printer.**

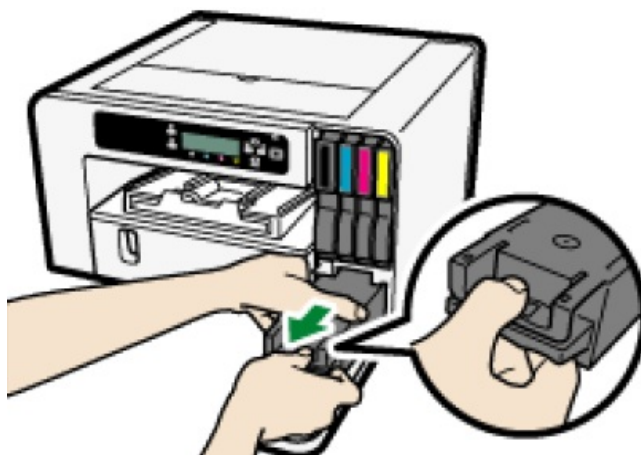

Press on the area marked "PUSH" to pull the unit out. Keep the unit level.

**4. Put the waste collection unit in the supplied plastic bag.**



5. Insert the new waste collection unit.

[Back to the top](#)

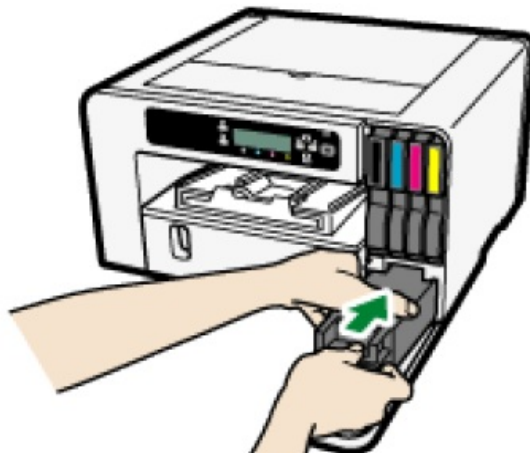

6. Slide the waste collection unit carefully into the printer until you hear it click.

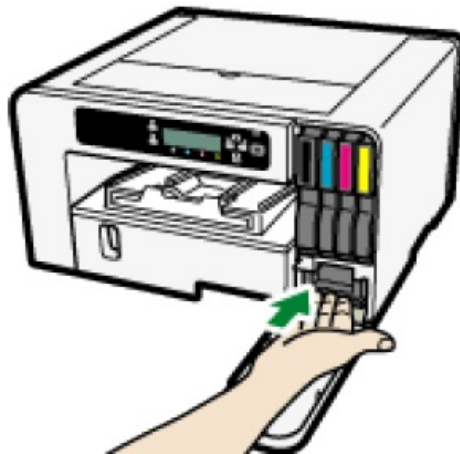

7. Close the right front cover.

## Cleaning

Clean the outside of the printer regularly to maintain the condition of the printer.

! Warning:

- Do not remove any covers or screws other than those explicitly mentioned in this manual. Inside this printer are high voltage components that are an electric shock hazard. Contact Sawgrass if any of the printer's internal components require maintenance, adjustment, or repair.
- Do not attempt to disassemble or modify this printer. Doing so risks burns and electric shock.

**! Warning:**

- When performing maintenance on the printer, always disconnect the power cord from the wall outlet.

To clean the exterior of the printer, wipe it with a soft, dry or damp cloth. If the dirt does not come off, wipe the printer first with a cloth moistened with a neutral detergent, then with a damp cloth, and finally with a dry cloth.

**★ Important**

- Do not use volatile chemicals like benzene or thinner, or insecticides on the printer. Using these chemicals could deform, crack, or change the color of the printer.
- When wiping the printer with a cloth moistened with detergent, be sure to wipe only the exterior.

### Cleaning the Power Cable Plug

This section describes precautions for cleaning the power cable plug.

**! Warning:**

- Be sure to disconnect the plug from the wall outlet at least once a year and check for the following:
  - There are burn marks on the plug.
  - The prongs on the plug are deformed.
- If any of the above conditions exist, do not use the plug and consult Sawgrass. Use of the plug could result in fire or electric shock.
- Be sure to disconnect the power cord from the wall outlet at least once a year and check for the following:
  - The power cord's inner wires are exposed, broken, etc.
  - The power cord's coating has a crack or dent.
  - When bending the power cord, the power turns off and on.
  - Part of the power cord becomes hot.
  - The power cord is damaged.
- If any of the above conditions exist, do not use the power cord and consult Sawgrass. Use of the power cord could result in fire or electric shock.

**! Caution:**

- Be sure to disconnect the plug from the wall outlet and clean the prongs and the area around the prongs at least once a year. Allowing dust to build up on the plug constitutes a fire hazard.

### Moving

The precautions when moving the printer a short distance or long distance are explained.

#### Moving a Short Distance

Take the following precautions when moving the printer a short distance - for instance, when attaching an optional paper tray or relocating the printer inside the same room.

**! Caution:**

- SG800NA and SG800EU weigh around 15 kg (33 lb.).
- Grip the center area at the base of the printer's sides. Lift it slowly and do not strain your body.
- When moving the printer, remove the option. Careless handling and over exertion when lifting can result in breakage and/or injury.
- Unplug the power cord from the wall outlet before you move the printer. While moving the printer, take care that the power cord is not damaged under the printer. Failing to take these precautions could result in fire or electric shock.

- When disconnecting the power cord from the wall outlet, always pull the plug, not the cord. Pulling the cord can damage the power cord. Use of damaged power cords could result in fire or electric shock.

### ★ Important

- Be sure to keep the printer level. If it is unduly tilted, ink will leak from the waste collection unit.

**1. Press and hold down the [Power] key until it turns off, then unplug the power cord.**

**2. Disconnect the USB cable or Ethernet cable.**

**3. If options are installed, remove it.**

See section “Attaching or Detaching Options” for more information.

**4. Lift the printer and move it to the place where you want to install it.**



Grip the indented area at the base of the printer's sides, as shown. Lift and carry the printer slowly and carefully.

- When you move the printer, unplug the power cord from the printer, too.
- Make sure the power cord is not trapped under the printer.

### Moving a Long Distance

To transport the printer, put it in the box it came in. Do the same for any options. If a box is needed, contact Sawgrass.

**! Caution:** Transporting the printer without ink cartridges or a waste collection unit installed will result in ink leaking out and damaging the printer.

- Do not remove the ink cartridges.
- Do not remove the Waste Collection Unit.
- Remove the paper.
- When you move the printer, also unplug the power cord from the printer.
- The inside of the printer may become dirty if the printer is not level when transported.

### Disposing

When disposing of the printer, be sure to comply with local disposal regulations.

## When Not Using for a Long Period of Time

! Caution:

- Sawgrass recommends that the printer be used often to ensure the print head nozzles do not become clogged.
- Sawgrass also recommends keeping the printer powered on at all times. This will allow the printer to run automatic maintenance utilities for optimal performance.
- The printer consumes a considerable of ink for maintenance and print head cleaning when used after a long period of inactivity.

### When not in use, be careful of the following:

- Even with automatic maintenance utilities, the nozzles of the print heads may dry out and become clogged. To prevent this, periodically print something.
- If you choose to ignore Sawgrass' recommendations and power the printer off during periods of inactivity, at least turn the printer on for a few minutes once every 20-25 days, even if you don't print anything.
- If you want to print something after the printer has not been used for a period of time, always check for missing nozzles by printing a nozzle check test pattern. See section "[Nozzle Check](#)" for more information.
- If necessary, clean the print heads up to five (5) times prior to printing. See section "[Head-cleaning](#)" for more information.
- If (5) head cleans do not clear missing nozzles, perform one (1) head flush. See section "[Head-flushing](#)" for more information.
- If there is no improvement after performing the steps above, contact Sawgrass.

## Troubleshooting

This chapter describes common troubleshooting procedures that are applicable to functions of the printer and what to do when paper misfeeds (become jammed inside the printer).

### Note

- More troubleshooting information, particularly related to the printer and color management software, is located on [sawgrassink.com](http://sawgrassink.com).

## Canceling Printing

Print jobs can be canceled from either a printer or computer. How to cancel print jobs differs according to their job status. Check the job status first.

### Canceling a print job already sent to the printer

| *Cancel the print job by pressing the [Job Reset] key.*

### Canceling a print job that is not sent to the printer

| *Cancel the print job from the taskbar of the computer.*

## Canceling Printing Using the [Job Reset] Key

Follow the procedure below to cancel a print job that was already sent to the printer.

The [Job Reset] key cancels all print jobs being printed or that were received. If you do not want to cancel another print job that was sent later, it's possible to delete only the current print job.

### Cancel only the print job being printed

1. **Check that printing has started.**
2. **Press the [Job Reset] key.**

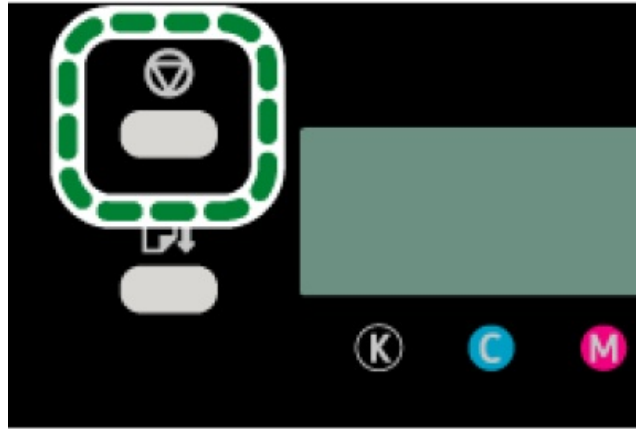

The confirmation screen appears.  
Job Reset?  
Current Job

3. Press the [#Enter] key.

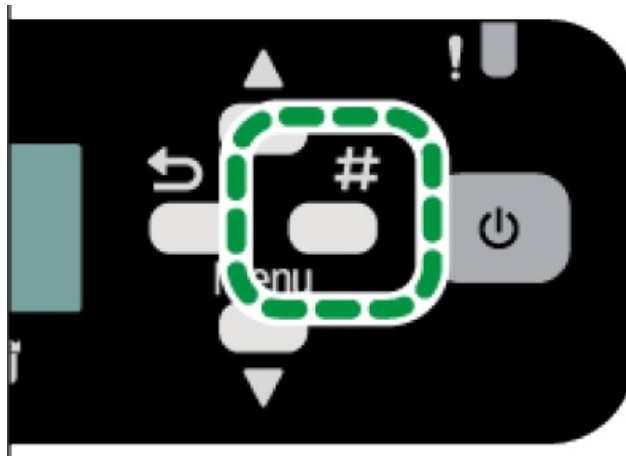

Only the print job being printed is deleted.

If there are other print jobs waiting, they will be printed after the current print job is deleted.

It takes time to cancel the print job.

### Cancel all print jobs received

1. Check that printing has started.
2. Press the [Job Reset] key.

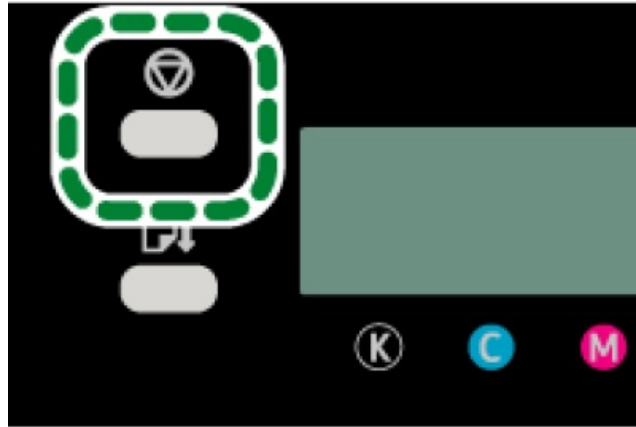

The confirmation screen appears.

Job Reset?  
Current Job

3. Press the [ ^ ] or [ ▼ /Menu] key to display [Job Reset? All Jobs], then press the [#Enter] key.

Job Reset?  
All Jobs

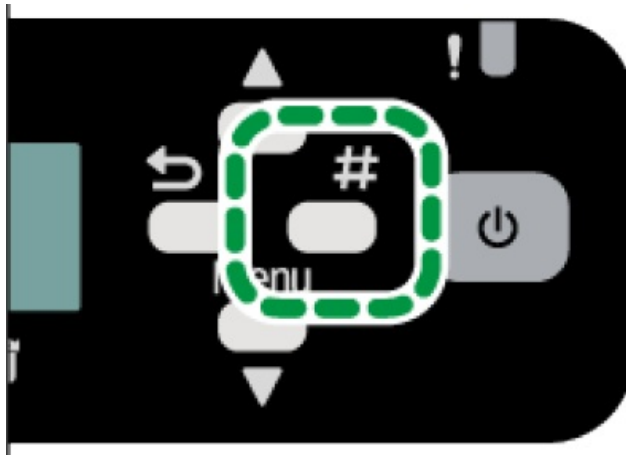

The confirmation screen appears.

Reset all  
received Jobs?

4. Press the [#ENTER] key.

All print jobs received will be canceled.  
It takes time to cancel the print job.

### Canceling Printing from the Windows Taskbar

Follow the procedure below to cancel a print job in the printer queue.

1. Double-click the printer icon on the taskbar.

2. Select the print job you want to cancel in the printer queue that is displayed. Click [Cancel] on the [Document] menu.

### Canceling a Print Job from the Macintosh Print Job Queue Window

You can delete a print job before, during, and after its being sent from the computer to the printer.

1. Check that the print job queue window opens.

2. In the print job queue window, select the print job you want to cancel.
3. Click [Delete Job] in the [Jobs] menu or [Delete] on the toolbar.

## Printing Does Not Start

If printing fails, check the following:

### Check the printer's power.

- The [Power] key is not lit.

| *Turn the printer on.*

| *See section "[Turning On/Off the Power](#)" for more information.*

- The power indicator does not light up or blink despite the [Power] key being pressed.
- Check whether the power cord is plugged into the receptacle properly.
- Plug another appliance that works into the receptacle to determine whether the receptacle is all right.
- If the problem persists, unplug the power cord and contact Sawgrass.

### Check the error message.

- If the error message appears on the display

See section "[Error & Status Messages on the Display](#)" for more information.

### Check the name associated with the printer's icon.

### Check communication issue with PowerDriver.

- This may occur if the printer is powered on and/or connected prior to the appropriate step during the installation of software.
- Visit [sawgrassink.com](http://sawgrassink.com) or contact Sawgrass for more information.

## Paper / Print Media Is Not Fed or Delivered Normally

If the printer is operating but paper / print media will not feed or paper jams multiple times, check the condition of the printer and paper / print media.

### Paper / print media does not feed smoothly.

- Paper guides are not adjusted correctly.

The paper guides of the paper tray do not match the paper / print media loaded. Adjust the paper guides and load the paper / print media again.

See section "[Loading Paper](#)" for more information.

- Paper / print media is not loaded correctly.

The paper / print media is not loaded correctly. Load the paper / print media correctly. See section "[Loading Paper](#)" for more information.

- Paper / print media is curled.

Remove the loaded paper / print media and check if it is curled. If it is, straighten the curl within 2 mm (0.08 inches).

### Paper / print media jams multiple times.

- Paper / print media is still jammed in the printer.

Pull the paper tray out, then open the output ramp to check for jammed paper.

### Multiple sheets of paper / print media are fed at one time.



- Load the paper / print media again. Remove the paper from the paper tray, fan it well, and tap it on a flat surface such as a desk to even the edges. Check the position of the paper guides of the paper tray, then load the paper / print media again.
- A double-feed may occur when using the bypass tray to print on paper / print media that has a rough surface or that is friction prone.
- If a double-feed occurs several times, use Trays 1, 2, or 3 to print.
- See sections "[Handling and Storage Precautions](#)" and "[Loading Paper](#)" for more information.

### **The paper / print media does not feed even after a paper jam has been cleared.**

- When a paper jam occurs, clear the paper jam, then press the [Form Feed] key. See "[Using the \[Form Feed\] Key to Remove Jammed Paper](#)" for more information.

## **Paper / Print Media Jam**

This section explains how to remove a paper / print media jam.

! Caution:

- When removing jammed paper / print media or replacing ink, avoid getting ink on your clothing. If ink comes into contact with your clothing, immediately rinse the stained area with cold water and wash the garment with laundry detergent per the care instructions provided on the label.
- When removing jammed paper / print media or replacing ink, avoid getting ink on your skin. If ink comes into contact with your skin, wash the affected area thoroughly with soap and water. If irritation develops, seek medical attention.
- When removing jammed paper, make sure not to trap or injure your fingers.

If a paper / print media jam error message appears on the display Web Image Monitor, remove the paper / print media according to the message.

### **Important**

- Before installing or removing options, always disconnect the power cord plug from the wall outlet.

### **Reference**

See sections listed below for more information:

- Using the [Form Feed] Key to Remove Jammed Paper.
- Continue to remove the jammed paper according to subsequent error messages until the messages no longer appear. See section "[Removing Paper / Print Media Jammed in Tray 1](#)" for more information.
- "[Paper Jam](#)" for more information.
- If paper jams occur repeatedly, see section "[Paper Is Not Fed or Delivered Normally](#)" for more information.
- [Paper Jam in Tray 1](#).
- Continue to remove the jammed paper according to subsequent error messages until the messages no longer appear. See section [Paper / Print Media Jam in Tray 2/3](#) for more information.
- [Paper Jam](#)" for more information.
- If paper jams occur repeatedly, see section "[Paper Is Not Fed or Delivered Normally](#)" for more information.
- [Paper Jam in Tray 2/3](#)".
- Continue to remove the jammed paper according to subsequent error messages until the messages no longer appear. See section "[Removing Paper / Print Media Jammed in the Bypass Tray](#)" for more information.
- "[Paper Jam](#)" for more information.
- If paper jams occur repeatedly, see section "[Paper Is Not Fed or Delivered Normally](#)" for more information.
- "[Removing Paper Jammed in the Bypass Tray](#)".
- "[Removing Paper Jammed under the Top Cover](#)".
- "[Removing Paper Jammed in Tray 2/3](#)".
- "[Opening the Rear Unit Cover to Remove Jammed Paper](#)"

## Using the [Form Feed] Key to Remove Jammed Paper

1. Press the [Form Feed] key.

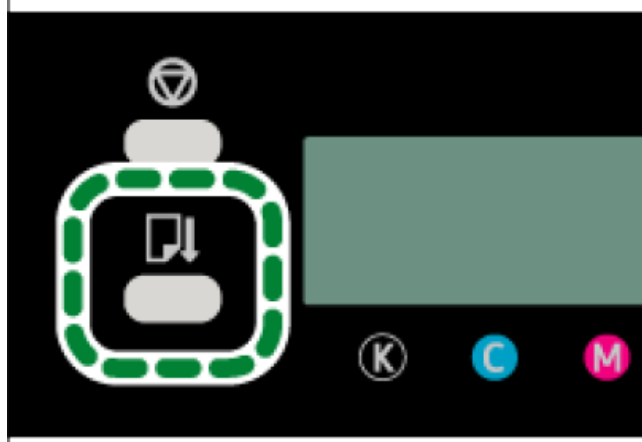

2. Remove the jammed paper.

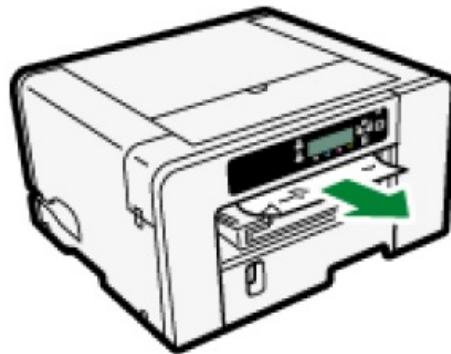

Printing starts.

- Continue to remove the jammed paper according to subsequent error messages until the messages no longer appear. See section " " for more information.
- "Paper Jam" for more information.
- If paper jams occur repeatedly, see section "Paper Is Not Fed or Delivered Normally" for more information.

## Removing Paper / Print Media Jammed in Tray 1

1. Hold the grip on Tray 1, lift the tray slightly ① , then pull it out ② .

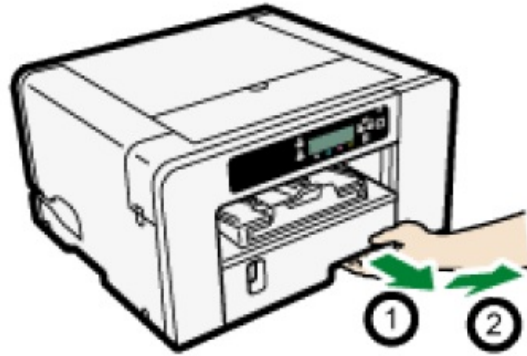

Pull the tray completely out. Take care not to drop it.

**2. Open the output ramp, then remove the jammed paper / print media.**

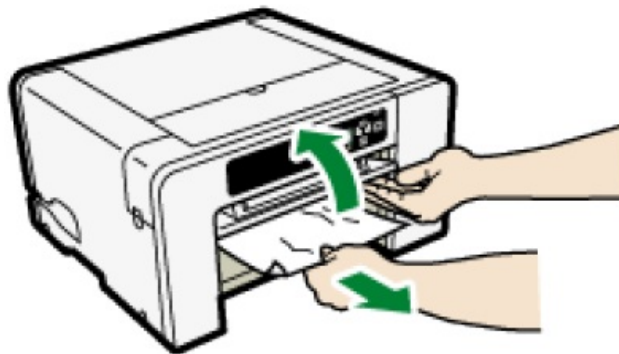

If you cannot remove the jammed paper / print media or it is difficult to remove, the paper / print media may be jammed inside the printer. Examine the paper / print media carefully and remove.

**3. Close the output ramp.**



**4. Push Tray 1 gently in until it stops.**

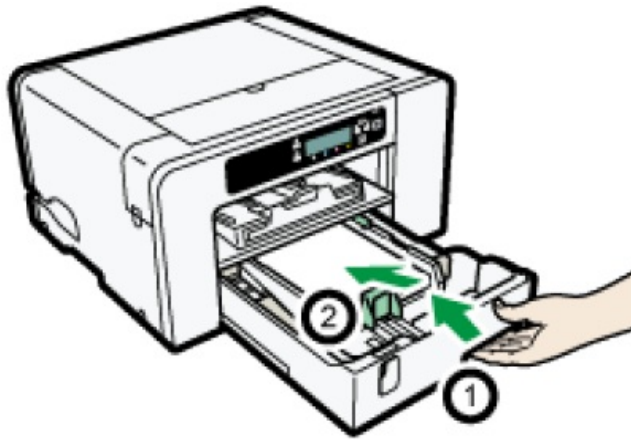

Before pushing the paper tray in, make sure the output ramp is closed.

Printing starts. Blank paper / print media may be delivered after printing resumes.

#### **Note**

- Continue to remove the jammed paper according to subsequent error messages until the messages no longer appear. See section "[" for more information.](#)"
- "[Paper Jam](#)" for more information.
- If paper / print media jams occur repeatedly, see section "[Paper Is Not Fed or Delivered Normally](#)" for more information.

### **Paper / Print Media Jam in Tray 2/3**

#### **1. Remove the paper / print media jammed in Tray 2/3.**

| See section "[Removing Paper Jammed in Tray 2/3](#)" for more information.

#### **2. Open the rear unit cover and remove the jammed paper / print media.**

See section "[Opening the Rear Unit Cover to Remove Jammed Paper](#) ( for more information.

#### **Note**

- Continue to remove the jammed paper / print media according to subsequent error messages until the messages no longer appear. See section "[Paper / Print Media Jam](#)" for more information.
- "[Paper Jam](#)" for more information.
- If paper jams occur repeatedly, see section "[Paper Is Not Fed or Delivered Normally](#)" for more information.

### **Removing Paper / Print Media Jammed in the Bypass Tray**

#### **1. Remove any paper / Print Media in the bypass tray.**

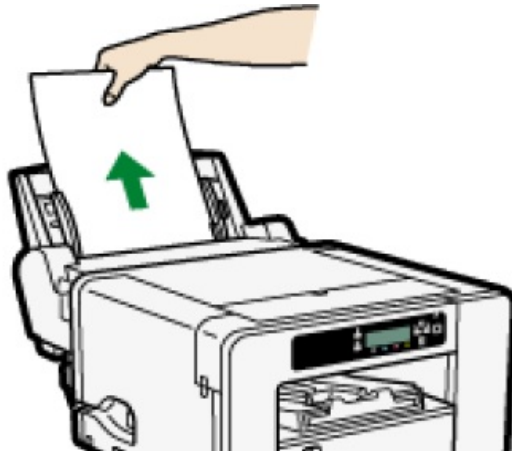

2. Remove the jammed paper / print media.

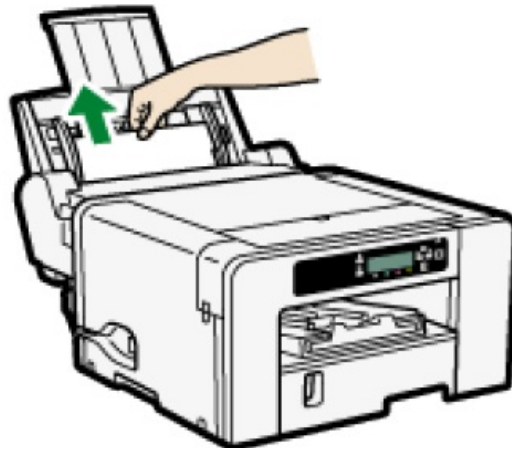

3. Load paper / print media in the bypass tray with the side to be printed on facing up and without exceeding the sheet limit.

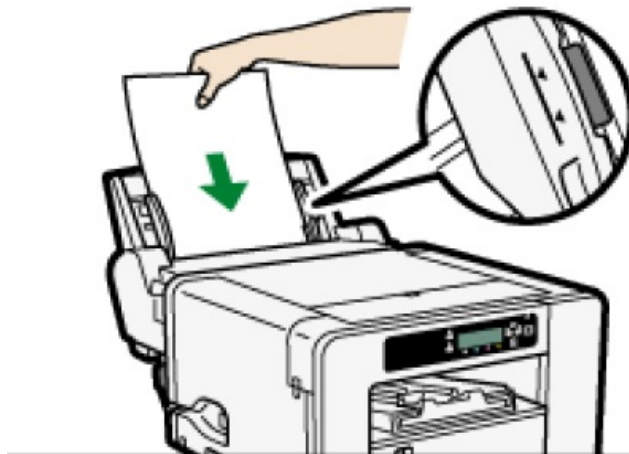

4. Press the [Form Feed] key.

Printing starts. Blank paper / print media may be delivered after printing resumes.

If it is difficult to remove the jammed paper / print media, detach the bypass tray so **that the paper / print media can be removed.**

Detach the bypass tray.

See section “Attaching and Detaching the Bypass Tray” for more information.

**1. Remove the jammed paper / print media from the rear of the printer.**



### Reattach the bypass tray.

See section ["Attaching and Detaching the Bypass Tray"](#) for more information.

### 2. Load paper / print media in the bypass tray with the side to be printed on facing up and without exceeding the sheet limit.

#### Note

- Continue to remove the jammed paper according to subsequent error messages until the messages no longer appear. See section ["Paper / Print Media Jam"](#) for more information.
- ["Paper Jam"](#) for more information.
- If paper jams occur repeatedly, see section ["Paper Is Not Fed or Delivered Normally"](#) for more information

#### Removing Paper / Print Media Jammed under the Top Cover

#### Important

- Do not touch the feed belt, ink tubes, paper pressing board, or toothed rubber belt. Also, take care not to catch cables or ink tubes with your sleeves.

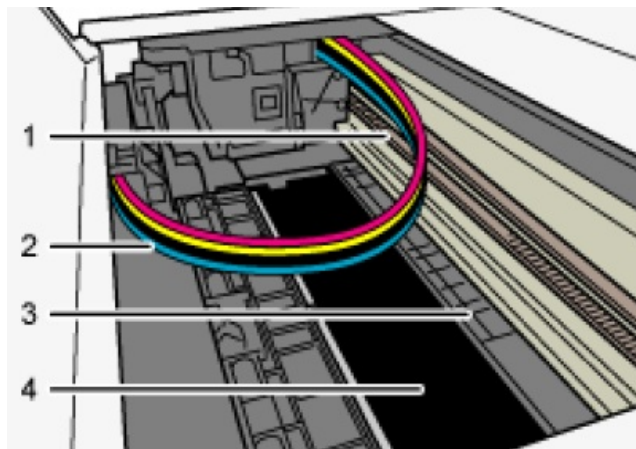

1. *Toothed rubber belt*

2. *Ink tube*

3. Paper pressing board

4. Feed belt

1. Open the top cover.



2. Press the [Form Feed] key.

3. Remove the jammed paper / print media through the top cover opening.

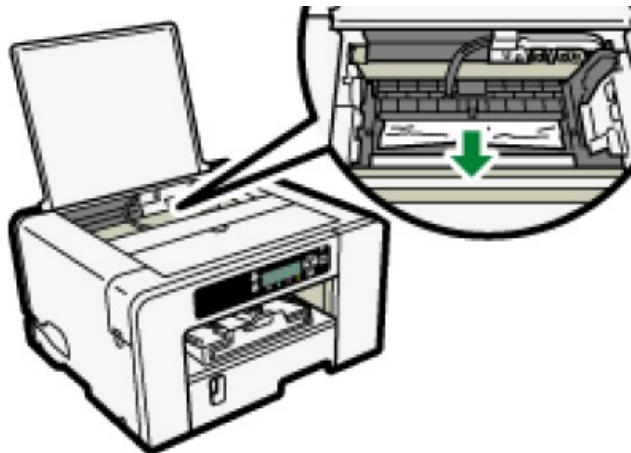

When removing the paper / print media, slowly pull it obliquely upward. Pulling it forcibly or directly upward may cause some parts to come off.

If the print head has stopped halfway, move it to either end.

4. Close the top cover.



Printing starts. Blank paper / print media may be delivered after printing resumes.

### 5. Print the nozzle check test pattern to make sure the print head's nozzles are not missing.

See section "[Nozzle Check](#)" for more information.

#### Note

- Continue to remove the jammed paper / print media according to subsequent error messages until the messages no longer appear. See section "[Paper / Print Media Jam](#)" for more information.
- "[Paper Jam](#)" for more information.
- If paper jams occur repeatedly, see section "[Paper Is Not Fed or Delivered Normally](#)" for more information.

### Opening the Rear Cover to Remove Jammed Paper / Print Media

1. Slide the tabs on the sides to unlock, then open the rear cover.

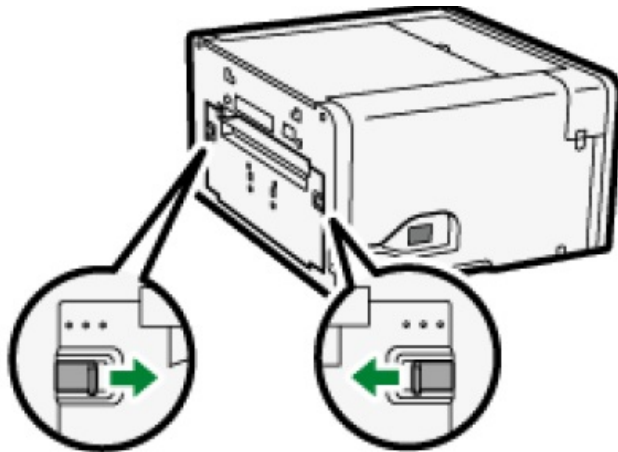

2. Remove the jammed paper / print media.





3. Close the rear cover.

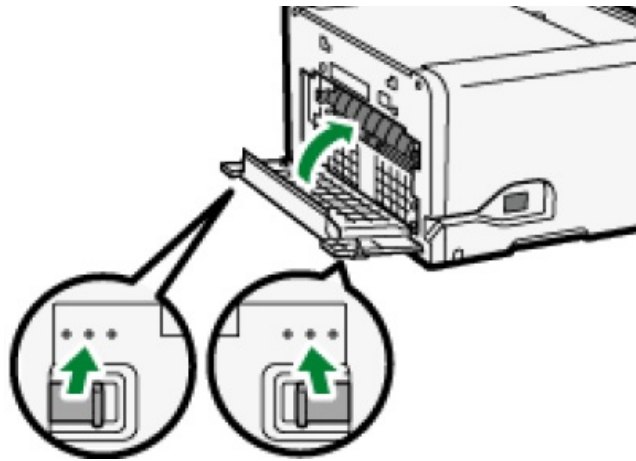

Make sure to return the tabs to their original positions.

Printing starts. Blank paper / print media may be delivered after printing resumes.

- Continue to remove the jammed paper according to subsequent error messages until the messages no longer appear. See section ["Removing Paper / Print Media Jammed in the Bypass Tray"](#) for more information.
- ["Paper Jam"](#) for more information.
- If paper jams occur repeatedly, see section ["Paper Is Not Fed or Delivered Normally"](#) for more information.

### Removing Paper / Print Media Jammed in Tray 2/3

1. Hold the grip on Tray 2/3, lift the tray slightly ①, then pull it out ②.

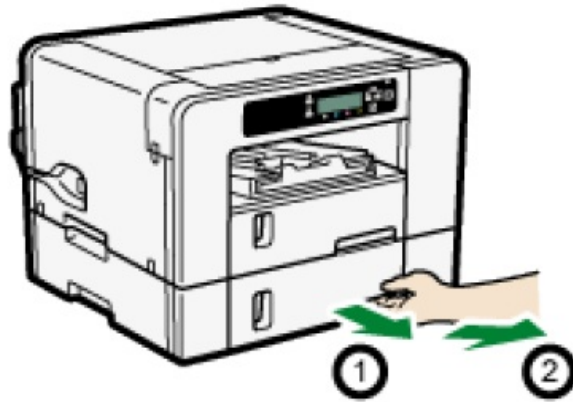

Pull the tray completely out. Take care not to drop it.

**2. Remove the jammed paper / print media.**



**3. Push Tray 2/3 gently in until it stops.**

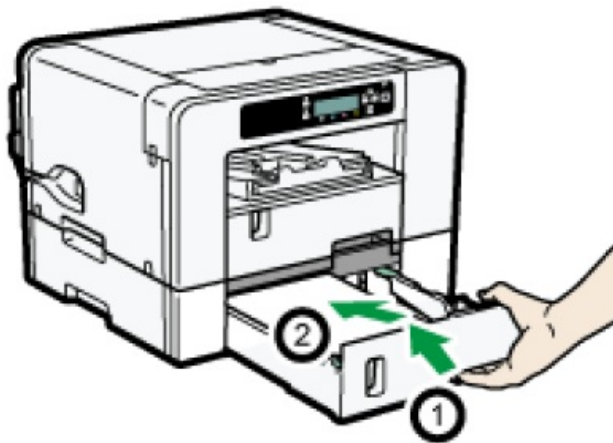

Printing starts. Blank paper / print media may be delivered after printing resumes.

**Note**

- Continue to remove the jammed paper according to subsequent error messages until the messages no longer appear. See section ["Paper / Print Media Jam"](#) for more information.
- ["Paper Jam"](#) for more information.
- If paper jams occur repeatedly, see section ["Paper Is Not Fed or Delivered Normally"](#) for more information.

## Opening the Rear Unit Cover to Remove Jammed Paper / Print Media (SG400NA/SG400EU)

1. Slide the tabs on the sides to unlock, then open the rear unit cover.

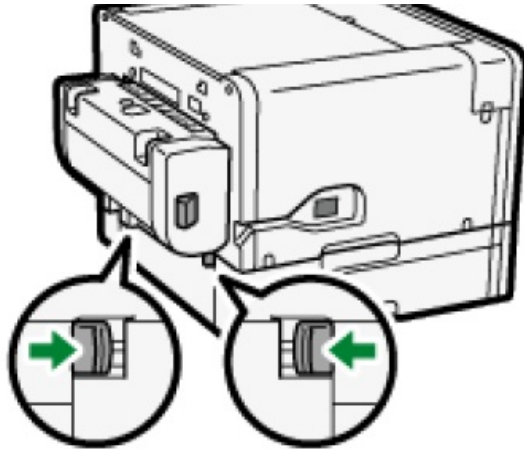

2. Remove the jammed paper / print media.

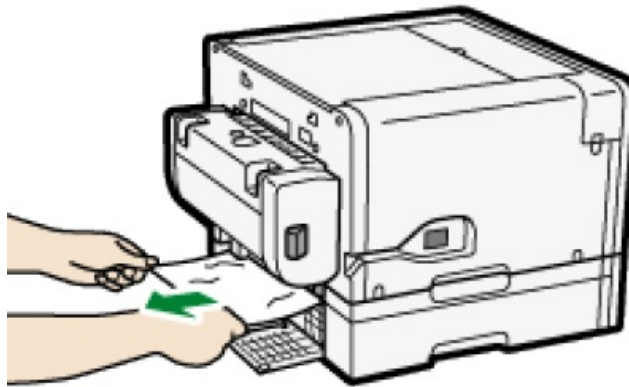

3. Close the rear unit cover.

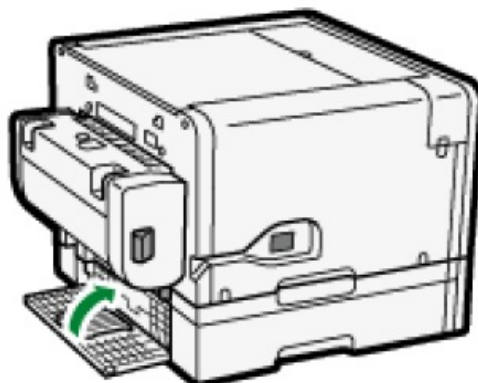

Make sure to return the tabs to their original positions.  
Printing starts. Blank paper / print media may be delivered after printing resumes.

#### Note

- Continue to remove the jammed paper according to subsequent error messages until the messages no longer appear. See section "[Paper / Print Media Jam](#)" for more information.
- "[Paper Jam](#)" for more information.
- If paper jams occur repeatedly, see section "[Paper Is Not Fed or Delivered Normally](#)" for more information.

### Poor Print Quality

If print quality is poor, check the printer and printer driver and design software settings for problems. If no problems are apparent, check the "Recommended Use by Date" for the ink cartridges or issues with the sublimation paper. For details about handling paper, see section "[Loading Transfer Paper / FabricMaker Media](#)" for more information. For details about handling the ink cartridges, see section "[Handling Ink Cartridges](#)" for more information.

#### Note

- If problems persist visit [sawgrassink.com](http://sawgrassink.com) for more troubleshooting information.

### Prints are Unsatisfactory

This section explains how to troubleshoot the printer when printing is uneven or when prints are streaked, smudged, smeared, or blotchy.

#### Have you printed the nozzle check test pattern?

Print the nozzle check test pattern to check whether the print head nozzles are all ejecting ink properly, and, if necessary, carry out head cleaning and/or head-flushing.

- If necessary, clean the print heads up to five (5) times prior to printing. See section "[Head-cleaning](#)" for more information.
- If (5) head cleans do not clear missing nozzles, perform one (1) head flush. See section "[Head-flushing](#)" for more information.

#### Has the printer not been used for a long time?

The ink may be dry causing the print head nozzles to become clogged. Print the nozzle check test pattern and clean the print heads as necessary. See section "When not Using for a Long Period of Time" for more information.

#### Have the print heads been aligned?

Blurred or double lines indicate the print heads may be incorrectly positioned. See section "Using the [Maintenance] Menu" for more information.

#### Is there a problem with the printer's location?

Make sure that the printer is level. Place the printer in a location where it will not be subject to shaking or excessive force.

See section "[Checking the Installation Area](#)" for more information.

#### Have you performed registration?

Perform registration if the print start point indicates misalignment.

After attaching the option tray, and the bypass tray, you must register where to start printing on paper / print media loaded in each paper tray.

See section "[Registration](#)" for more information.

#### Have you changed the paper feed setting?

If horizontal lines are printed unaligned, print images are patchy, or black or white streaks are printed at regular intervals, print a test pattern, then adjust the paper feed setting.

See section "[Adjust Paper Feed](#)" for more information.

## Does the paper type setting match?

Make sure that the paper type setting of the printer driver matches the type of paper loaded.

See section "Using the [Paper Input] Menu" for more information.

## Have any of the inks past the "Recommended Use by Dates"?

Ink cartridges should be used prior to the "Recommended Use by Date," preferably within six months of being removed from their packaging. Using ink in the printer past this date may be harmful to the unit and/or result in poor output quality.

## Are you printing on the right type or wrong side of the paper / print media?

Check that you are printing on transfer paper / print media and that the print is on the correct side.

See sections "Handling and Storage Precautions" and "Loadable Paper Sizes Paper" for more information.

## Is the paper / print media loaded in the correct orientation?

Some paper / print media cannot be loaded lengthwise depending on the size of the paper / print media. Check the orientation in which the paper / print media is loaded.

See section "Loadable Paper Sizes" for more information.

## Colors are not correct

If the color of the printed output differs from what is expected, refer to the following questions:

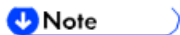

More information specifically regarding color can be found on [sawgrassink.com](http://sawgrassink.com).

## Does color not match what is onscreen?

Since printed colors and screen colors are produced by different methods, a color printed and a color displayed on a screen can have different hues even though they are the "same" color.

## Has the nozzle check been performed?

The print heads may be missing nozzles. Print the nozzle check test pattern and clean the print heads as necessary.

See sections "Nozzle Check" and "Head-cleaning" for more information.

## Are you printing on the right type or wrong side of the paper / print media?

Check that you are printing on transfer paper / print media and that the print is on the correct side.

See sections "Handling and Storage Precautions" and "Loading Paper" for more information.

## Have any of the inks past the "Recommended Use by Dates"?

Ink cartridges should be used prior to the "Recommended Use by Date," preferably within six months of being removed from their packaging. Using ink in the printer past this date may be harmful to the unit and/or result in poor output quality.

## Is a supported design software being used and is it configured properly?

Certain types of design software are required for correct color output. Poor color quality will likely occur if specified software is not used or configured properly.

See section "Design Software Requirements" for more information.

## Image Position is not Correct or Only a Partial Image is Printed

If the position of printed items is not correct or only a partial image is printed, refer to the following questions:

## Have the settings for page layout been made?

Check whether page layout settings have been made with the design software.

## Does the paper size setting match?

Make sure that the paper size selected in the [Print On:] list of the [Printer Properties] dialog box matches the size of the paper loaded.

## Is there a printer error?

View the display or Web Image Monitor to check whether an error has occurred.

## Is the correct paper size selected in the design software and printer driver?

Make sure that the paper size selected in design software and printer driver matches the size of the paper loaded.

## Does the computer meet system requirements?

Check that the computer being used meets system requirements. See section "System Requirements" for more information.

## Error & Status Messages on the Display

This section explains what the messages that appear on the display mean and what to do when a particular message appears.

Depending on the "Auto Continue" settings specified on the [System] menu, some of the following messages might not appear. See section "[Using the \[System\] Menu](#)" for more information.

### Error Messages

#### Cannot recover error page(s) / FormFeed to print remaining

The printer confirmed that the error has been cleared and printing has resumed. However, some page(s) did not print.

To continue printing, press the [Form Feed] key and print the missing page after the print job is finished. To delete the print job, press the [Job Reset] key.

See section "[Cannot Recover Error Page](#)" for more information.

#### Cannot use High Temp. / Power Off On

The temperature is abnormally high.

Check the installation area and relocate the printer. Alternatively, wait until the printer acclimates to the room temperature.

See section "[Out of Printable Temperature Range](#)" for more information.

#### Cannot use Low Temp. / Power Off On

The temperature is abnormally low.

Check the installation area and relocate the printer. Alternatively, wait until the printer acclimates to the room temperature.

See section "[Out of Printable Temperature Range](#)" for more information.

### Paper Size or Type Mismatch

The size of paper in the tray # (Tray 1, 2, 3, or the bypass tray) is different from the size specified.

Load the paper / print media of the size specified in the paper tray, then change the paper size in the paper input menu accordingly.

Alternatively, press the [Form Feed] key, select a paper tray containing paper of the specified size, then print. To cancel the print job, press the [Job Reset] key.

See sections "[See section "Cancelling Printing" for more information.](#)"

[Paper Size Mismatch/Paper Type Mismatch \(Tray 1\)](#)" and ["See section "Cancelling Printing" for more information.](#)

[Paper Size Mismatch/Paper Type Mismatch \(Tray 1\)](#) for more information.

### **Hardware Problem Ethernet Board**

An error in the Ethernet port (ethernet board) network function has occurred. Disconnect all cables, turn the printer off, and then turn it on again.

If the message reappears, contact Sawgrass.

See section ["Network Interface Error"](#) for more information.

### **Waste Collection Unit is not set / Set the Waste Collection Unit.**

The waste collection unit has not been installed correctly. Reset the waste collection unit correctly.

See section ["Waste Collection Unit Not Detected"](#) for more information.

### **Waste Collection Unit is full / Replace Waste Collection Unit**

The waste collection unit is full. Replace the waste collection unit.

See section ["Waste Collection Unit"](#) for more information.

### **Load Paper or Form Feed**

There is no paper trays that contain paper / print media of the specified size and type. Load paper / print media of the specified size and type in a paper tray, then specify the size and type in the paper input menu accordingly.

Alternatively, press the [Form Feed] key, select a paper tray containing paper / print media of the specified size or type, then print. To cancel the print job, press the [Job Reset] key. See section ["Paper Size Mismatch/Paper Type Mismatch \(Auto Tray Select\)"](#) for more information.

### **Load Paper:Tray# or Form Feed**

The tray (Tray 1, 2, 3, or the bypass tray) has run out of paper / print media.

Reload the paper tray.

Alternatively, press the [Form Feed] key, select a different paper tray, then print. To cancel the print job, press the [Job Reset] key.

See sections ["No Paper/Tray Not Detected \(Tray 1\)"](#) for more information.

### **Load Paper:Tray1**

Tray 1 has run out of paper / print media. Reload Tray 1.

To cancel the print job, press the [Job Reset] key.

See section ["No Paper/Tray Not Detected \(Tray 1\)"](#) for more information.

### **Loading Ink... / WAIT! N minutes**

Ink being filled.

"N" indicates time required for this operation.

### **Low Ink**

The ink will soon run out.

Make sure you have a new ink cartridge for the color indicated by the  icon.

### **Maintenance failed**

Head cleaning, head flushing, or other maintenance operations have failed. Run the maintenance again after clearing the error.

You can clear a maintenance error as follows:

- The printer receives another print job.
- Press the [#Enter] key.

### **Maintenance in process...**

The printer is cleaning or flushing its print head. Wait a moment.

### **Open Front Cover / Replace Ink Crtg**

The ink has run out.

Install a new ink cartridge indicated by the  or  icon. See section "[Ink Cartridge](#)" for more information.

### **Open Front Cover / Reset Cartridge**

No ink cartridge has been installed. Install the ink cartridge correctly.

See section "[Cover Open / Ink Cartridge\(s\) Not Detected](#)" for more information.

### **Page Drying...**

Being dried.

See section "[Using the \[Maintenance\] Menu](#)" for more information.

**Panel Locked Cannot use** You have pressed a locked key. Unlock the key.

### **Paper Misfeed / Press Form Feed**

A paper / print media jam occurs.

Press the [Form Feed] key to feed the paper / print media.

See section "[Using the \[Form Feed\] Key to Remove Jammed Paper](#)" for more information.

### **Paper Misfeed Bypass Tray / Reset Paper**

A paper / print media misfeed has occurred in the bypass tray. Reposition the paper / print media in the bypass tray.

See section "[Loading Paper](#)" for more information.

### **Paper Misfeed Remove all Rear / Covers then remove misfeed**

A paper / print media jam occurs.

Open the rear cover or rear unit cover, then remove the jammed paper / print media.

See sections "[Opening the Rear Cover to Remove Jammed Paper](#)" and "[Opening the Rear Unit Cover to Remove Jammed Paper](#)" for more information.

### **Paper Misfeed remove Tray # / or Rear Covers, remove misfeed**

Paper / print media has jammed in the tray (Tray 2 or 3). Remove the jammed paper / print media.

See section "[Paper Jam in Tray 2/3](#)" for more information.

### **Paper Misfeed Tray # / Remove tray(s), reset paper**

A paper / print media misfeed has occurred in the tray (Tray 1, 2, or 3).

Reposition the paper / print media in the paper tray, then press the [Form Feed] key. See section "[Loading Paper](#)" for more information.





## Prepare new Waste Collection Unit

The waste collection unit is almost full.

Make sure you have a new waste collection unit on hand.

If an ink cartridge starts running out of ink when the waste collection unit is almost full, the alert indicator will flash and a message informing you of the cartridge's low ink level will appear on the display.

## Processing...

The printer is printing.

## Ready

The printer is able to print.

## Rear Cover is open / Close Rear Cover

The rear cover is open.

Close the rear cover.

See section "[Cover Open](#)" for more information.

## Remove Misfeed Open Top Cover / Press Form Feed, remove misfeed

A paper / print media jam occurs.

Open the top cover, press the [Form Feed] key, then remove the jammed paper / print media from the opening.

See section "[Removing Paper Jammed under the Top Cover](#)" for more information.

## Reset Bypass Tray correctly

The bypass tray has not been installed correctly. Reset the bypass tray correctly.

See section "Attaching and Detaching the Bypass Tray" and "No Paper/Tray Not Detected (Bypass Tray)" for more information.

## Resetting Job...

The printer is reinitializing a print job. Wait a moment.

## Right Front Cover is open / Close Right Front Cover

The right front cover is open. Close the ink cartridge cover.

See section "[Cover Open / Ink Cartridge\(s\) Not Detected](#)" for more information.

## Right Int. Unit almost full

Internal unit is a service replacement part.

For details about internal unit replacement, contact Sawgrass.

## SCXXX-XX Power Off On / Call Service if error reoccurs

An error has occurred.

Turn the printer off and then on. If the message reappears, contact Sawgrass.

## Setting change...

The printer is updating the network interface. Wait a moment.

### Temp. alert Please wait...

The printer is too hot or cold at start-up. Wait until "Ready" appears on the display.

### Top Cover is open / Close Top Cover

The top cover is open. Close the top cover.

See section "[Cover Open](#)" for more information.

### Tray # Rear Cover is open / Close Tray # Rear Cover

The rear unit cover of the tray (Tray 2 or 3) is open. Close the rear unit cover.

See section "[Cover Open](#)" for more information.

### Used Ink Collect Unit is set / Replace Ink Collector Unit

A used waste collection unit was installed. Install a new waste collection unit.

See section "[Waste Collection Unit](#)" for more information.

### Used Ink Cartridge / Replace Ink Cartridge

A used ink cartridge was installed.

Replace the ink cartridge indicated by the  or . See section "[Ink Cartridge](#)" for more information.

### Waiting...

Wait a moment.

### Errors Displayed by the Web Image Monitor

If an error occurs with the printer, the Web Image Monitor displays an error message. Check the manual for the page corresponding to the error where you can check how to resolve the problem in more detail.

Depending on the "Auto Continue" settings specified on the [System] menu, some of the following messages might not appear. See section "[Using the \[System\] Menu](#)" for more information.

#### No Paper/Tray Not Detected (Tray 1)

Tray 1 has run out of paper / print media or the tray is not installed correctly. Follow the procedure below:

- Load paper / print media into the paper tray.

See section "[Loading Paper](#)" for more information.

- Print by Form Feed.

Press the [Form Feed] key, select a different paper tray, then print.

- Cancel the print job.

See section "Cancelling Printing" for more information.

#### No Paper/Tray Not Detected (Tray 2/3)

Tray 2/3 has run out of paper / print media or the tray is not installed correctly. Follow the procedure below:

- Load paper / print media into the paper tray.

See section "[Loading Paper](#)" for more information.

- Print by Form Feed.

Press the [Form Feed] key, select a different paper tray, then print.

- Cancel the print job.

See section “Cancelling Printing” for more information.

### **No Paper/Tray Not Detected (Bypass Tray)**

The bypass tray has run out of paper / print media or the bypass tray is not installed correctly.

Follow the procedure below:

- Load paper / print media into the paper tray.

See section "[Loading Paper](#)" for more information.

- Attach the bypass tray properly.

See section “Attaching and Detaching the Bypass Tray” for more information.

- Print by Form Feed.

Press the [Form Feed] key, select a different paper tray, then print.

- Cancel the print job.

See section “Cancelling Printing” for more information.

### **Paper Size Mismatch/Paper Type Mismatch (Tray 1)**

Tray 1 is not loaded with paper / print media of the correct size or type. Follow the procedure below:

- Change the paper settings.

See section "[Using the \[Paper Input\] Menu](#)" for more information.

- Print by Form Feed.

Press the [Form Feed] key, select a paper tray containing paper of the specified size or type, then print.

- Cancel the print job.

See section “Cancelling Printing” for more information.

### **Paper Size Mismatch/Paper Type Mismatch (Tray 2/3)**

Tray 2/3 is not loaded with paper / print media of the correct size or type. Follow the procedure below:

- Change the paper settings.

See section "[Using the \[Paper Input\] Menu](#)" for more information.

- Print by Form Feed.

Press the [Form Feed] key, select a paper tray containing paper of the specified size or type, then print.

- Cancel the print job.

See section “Cancelling Printing” for more information.

### **Paper Size Mismatch/Paper Type Mismatch (Bypass Tray)**

The bypass tray is not loaded with paper / print media of the correct size or type. Follow the procedure below:

- Change the paper settings.

See section "[Using the \[Paper Input\] Menu](#)" for more information.

- Print by Form Feed.

Press the [Form Feed] key, select a paper tray containing paper / print media of the specified size or type, then print.

- Cancel the print job.

See section “Cancelling Printing” for more information.

## Paper Size Mismatch/Paper Type Mismatch (Auto Tray Select)

Paper tray is not loaded with paper / print media of the correct size or type. Follow the procedure below:

- Change the paper settings.

See section "[Using the \[Paper Input\] Menu](#)" for more information.

- Print by Form Feed.

Press the [Form Feed] key, select a paper tray containing paper / print media of the specified size or type, then print.

- Cancel the print job.

See section "Cancelling Printing" for more information.

## Cover Open

The top, rear, or rear unit cover is open. Close the cover.

If these covers are closed, open and close each of them again.

### 1. Close the cover. Top cover



### Rear cover

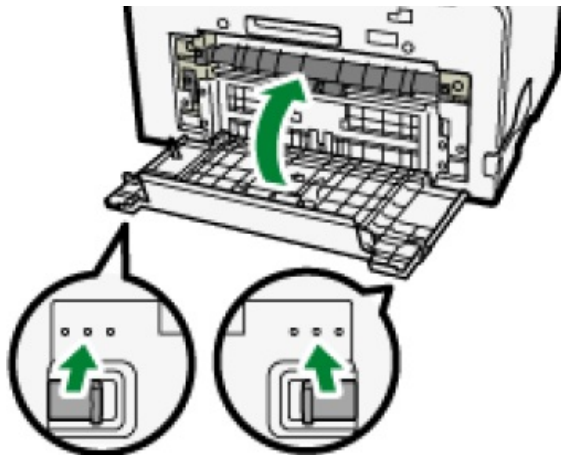

Make sure to return the tabs to their original positions.

## Cover Open / Ink Cartridge(s) Not Detected

The right front cover is open. Close the right front cover.

Alternatively, the ink cartridges are not installed or are installed incorrectly. Install the ink cartridges correctly.

If the cover is open

1. Close the right front cover.

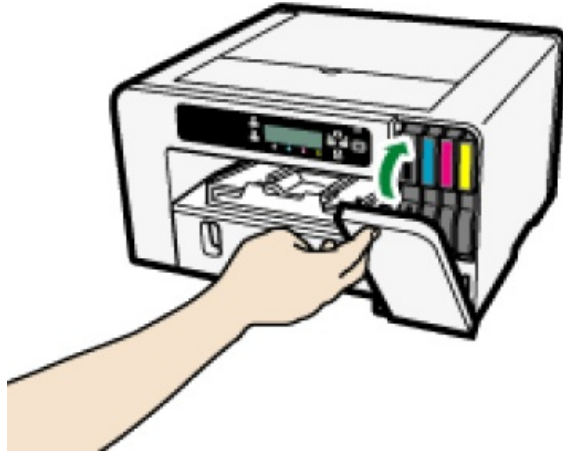

If the ink cartridges are not installed or are installed incorrectly

1. Open the right front cover.



2. Push the cartridge fully in.

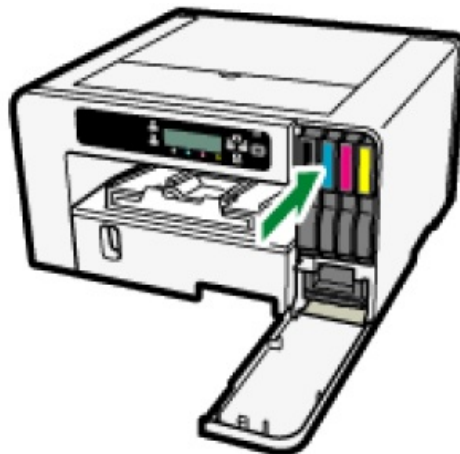

3. Close the right front cover.

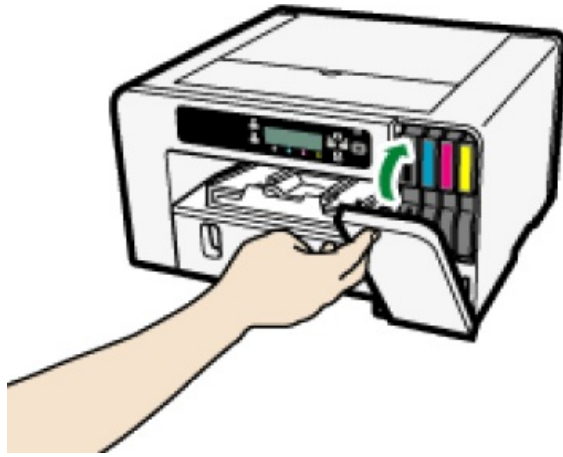

#### Note

- If the error persists, remove the ink cartridge, then re-install it. Do this once only.
- If there is a problem with the ink cartridge, try installing a new cartridge.
- For details about handling the ink cartridges, see section "[Handling Ink Cartridges](#)" for more information.

### Cartridge Almost Empty

One of the ink cartridges is almost empty.

Check which color ink cartridge will soon have to be replaced, then have a new cartridge handy.

#### Note

- Do not carry out head cleaning or head flushing. If you do, the ink may run out.
- If you turn the printer off then on again, the ink in the ink cartridge may run out.
- The amount of remaining ink shown in the cartridge replacement indicator is for reference only and may differ from the actual amount. Also, cartridges can become empty without a low ink warning appearing.

### Cartridge Empty

The ink has run out.

Replace the cartridge.

#### Note

- If the cartridge is empty, head cleaning or flushing cannot be performed.
- If the ink runs out during printing, the printer may eject blank or partially printed sheets.
- Cartridges that the printer report as empty may still contain a small amount of ink. This is normal as the cartridges are overfilled to prevent them from completely running dry. This prevents air from being drawn into the printer.

### Used Cartridge

A used ink cartridge was installed.

Replace the ink cartridge.

See section "[Ink Cartridge](#)" for more information.

#### Note

- If the cartridge is empty, head cleaning or flushing cannot be performed.
- Ink cartridges should be used up before the "Recommended Use By" date label affixed to each cartridge. Using ink in the printer past this date may be harmful to the unit and/or result in poor output quality.
- Cartridges that the printer report as empty may still contain a small amount of ink. This is normal as the cartridges are overfilled to prevent them from completely running dry. This prevents air from being drawn into the printer.

### Waste Collection Unit Not Detected

The waste collection unit is not inserted correctly. Insert the waste collection unit correctly.

1. Open the right front cover.



2. Attach the waste collection unit by pushing it in until it clicks.



3. Close the right front cover.

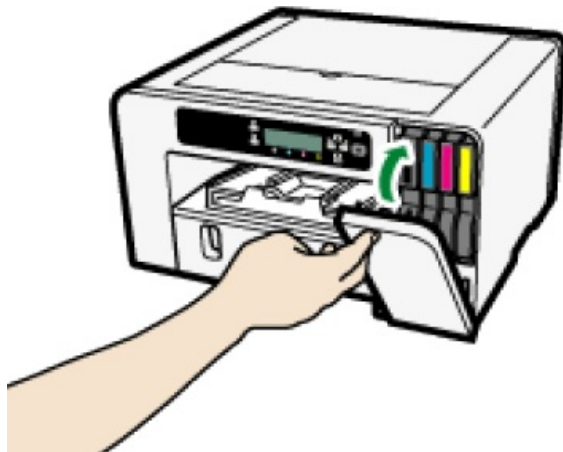

If the message reappears, contact Sawgrass.

### Waste Collection Unit Almost Full

The waste collection unit is almost full.  
Have a new waste collection unit handy.



- If an ink cartridge starts running out of ink when the waste collection unit is almost full, the alert indicator will flash and a message informing you of the cartridge's low ink level will appear on the display.

## Waste Collection Unit Full

The waste collection unit is full. Replace the waste collection unit.

See section "[Waste Collection Unit](#)" for more information.

## Used Waste Collection Unit

A used waste collection unit is installed.

Replace the waste collection unit.

See section "[Waste Collection Unit](#)" for more information.

## Out of Printable Temperature Range

Printing is not possible because the printer is placed in a location that is too hot or cold. Move the printer to a more suitable environment.

1. Press and hold down the [Power] key for one second.

2. **Place the printer in an environment where the temperature range is between 15°C and 25°C (59°F and 77°F).**

3. **Turn the printer on.**

### Note

- If humidity is more than 54%, the upper temperature limit will be lower.
- Even after the power is turned on, the printer may remain in standby mode until it acclimates to the room temperature. If this happens, wait until the [Power] key stops flashing and stays lit.

### Reference

- For details about what conditions the printer can be used under (ambient temperature and humidity range), see section "[Checking the Installation Area](#)" for more information.

## Printer Error

An error has occurred in the printer.

Turn the printer off, then turn it on again.

### Note

If the printer is relocated from a cold area to a warm area or the printer is placed in a room where the temperature varies greatly, condensation may form inside the printer causing errors. If this happens, perform the decondensation procedure. See section "[De-condensation](#)" for more information.

- If the error still does not clear after the printer acclimates to room temperature and the power is turned back on, contact Sawgrass.

## Network Interface Error

An error in the Ethernet port network function has occurred.

Turn the printer off, then turn it on again.

### Note

- If the message reappears, contact Sawgrass.

## Maintenance Failed

Head cleaning, head flushing, or other maintenance operations have failed. Run the maintenance again after clearing the error.

You can clear a maintenance error as follows:

- The printer receives another print job.
- Press the [#Enter] key.

## Cannot Recover Error Page

If you resume printing after removing a paper / print media jam, an error message may appear if some pages cannot be printed. If so, follow the procedure below:



- Print by Form Feed.

Press the [Form Feed] key, then the printer prints the remaining pages following the missed page(s).

- Cancel the print job.

See section "Cancelling Printing" for more information.

## Where to Inquire

For inquiries, contact Sawgrass or an authorized Sawgrass distributor.

## Recommended Consumables

Consumables recommended for this printer are listed. Purchase necessary consumables before your supply runs out.

For information about consumables, contact Sawgrass or an authorized Sawgrass distributor.

- Ink cartridges
- Waste Collection Unit

## Options

### **SG400OPTIONTRAY / SG800OPTIONTRAY**

This unit allows you to load additional sheets of paper / print media.

### **SG400BYPASSTRAY / SG800BYPASSTRAY**

Use this tray to feed in sheet manually and/or for oversize paper / print media.

For information about options, contact [Sawgrass](#) or an authorized Sawgrass distributor.

[Back to the top](#)

---

©2016 Sawgrass Inc. All rights reserved.

The information is based on information available at the time of publication and is subject to change without notice. Accuracy and completeness are not warranted or guaranteed.

The information contained in this document is confidential and provided under license. No part of this document may be reproduced or transmitted in any form or by any means, including electronic medium or machine-readable form, without the expressed written permission of Sawgrass Technologies, Inc.